

H61M-K



Motherboard

Copyright © 2013 ASUSTeK COMPUTER INC. All Rights Reserved.

No part of this manual, including the products and software described in it, may be reproduced, transmitted, transcribed, stored in a retrieval system, or translated into any language in any form or by any means, except documentation kept by the purchaser for backup purposes, without the express written permission of ASUSTeK COMPUTER INC. ("ASUS").

Product warranty or service will not be extended if: (1) the product is repaired, modified or altered, unless such repair, modification or alteration is authorized in writing by ASUS; or (2) the serial number of the product is defaced or missing.

ASUS PROVIDES THIS MANUAL "AS IS" WITHOUT WARRANTY OF ANY KIND, EITHER EXPRESS OR IMPLIED, INCLUDING BUT NOT LIMITED TO THE IMPLIED WARRANTIES OR CONDITIONS OF MERCHANTABILITY OR FITNESS FOR A PARTICULAR PURPOSE. IN NO EVENT SHALL ASUS, ITS DIRECTORS, OFFICERS, EMPLOYEES OR AGENTS BE LIABLE FOR ANY INDIRECT, SPECIAL, INCIDENTAL, OR CONSEQUENTIAL DAMAGES (INCLUDING DAMAGES FOR LOSS OF PROFITS, LOSS OF BUSINESS, LOSS OF USE OR DATA, INTERRUPTION OF BUSINESS AND THE LIKE), EVEN IF ASUS HAS BEEN ADVISED OF THE POSSIBILITY OF SUCH DAMAGES ARISING FROM ANY DEFECT OR ERROR IN THIS MANUAL OR PRODUCT.

SPECIFICATIONS AND INFORMATION CONTAINED IN THIS MANUAL ARE FURNISHED FOR INFORMATIONAL USE ONLY, AND ARE SUBJECT TO CHANGE AT ANY TIME WITHOUT NOTICE, AND SHOULD NOT BE CONSTRUED AS A COMMITMENT BY ASUS. ASUS ASSUMES NO RESPONSIBILITY OR LIABILITY FOR ANY ERRORS OR INACCURACIES THAT MAY APPEAR IN THIS MANUAL, INCLUDING THE PRODUCTS AND SOFTWARE DESCRIBED IN IT.

Products and corporate names appearing in this manual may or may not be registered trademarks or copyrights of their respective companies, and are used only for identification or explanation and to the owners' benefit, without intent to infringe.

Offer to Provide Source Code of Certain Software

This product contains copyrighted software that is licensed under the General Public License ("GPL"), under the Lesser General Public License Version ("LGPL") and/or other Free Open Source Software Licenses. Such software in this product is distributed without any warranty to the extent permitted by the applicable law. Copies of these licenses are included in this product.

Where the applicable license entitles you to the source code of such software and/or other additional data, you may obtain it for a period of three years after our last shipment of the product, either

(1) for free by downloading it from <http://support.asus.com/download>

or

(2) for the cost of reproduction and shipment, which is dependent on the preferred carrier and the location where you want to have it shipped to, by sending a request to:

ASUSTeK Computer Inc.
Legal Compliance Dept.
15 Li Te Rd.,
Beitou, Taipei 112
Taiwan

In your request please provide the name, model number and version, as stated in the About Box of the product for which you wish to obtain the corresponding source code and your contact details so that we can coordinate the terms and cost of shipment with you.

The source code will be distributed WITHOUT ANY WARRANTY and licensed under the same license as the corresponding binary/object code.

This offer is valid to anyone in receipt of this information.

ASUSTeK is eager to duly provide complete source code as required under various Free Open Source Software licenses. If however you encounter any problems in obtaining the full corresponding source code we would be much obliged if you give us a notification to the email address gpl@asus.com, stating the product and describing the problem (please DO NOT send large attachments such as source code archives, etc. to this email address).

Contents

Safety information.....	vi
About this guide.....	vii
H61M-K specifications summary.....	ix
Package contents.....	xii

Product introduction

1.1 Special features.....	1-1
1.1.1 Product highlights.....	1-1
1.1.2 ASUS Exclusive Features.....	1-2
1.2 Before you proceed.....	1-4
1.3 Motherboard overview.....	1-5
1.3.1 Placement direction.....	1-5
1.3.2 Screw holes.....	1-5
1.3.3 Motherboard layout.....	1-6
1.3.4 Layout contents.....	1-7
1.4 Central Processing Unit (CPU).....	1-7
1.4.1 CPU installation.....	1-8
1.4.2 CPU heatsink and fan assembly installation.....	1-10
1.5 System memory.....	1-12
1.5.1 Overview.....	1-12
1.5.2 Memory configurations.....	1-13
1.5.3 Installing a DIMM.....	1-20
1.6 Expansion slots.....	1-21
1.6.1 Installing an expansion card.....	1-21
1.6.2 Configuring an expansion card.....	1-21
1.6.3 PCI Express 2.0 x1 slot.....	1-21
1.6.4 PCI Express 3.0/2.0 x16 slot.....	1-22
1.7 Jumpers.....	1-23
1.8 Connectors.....	1-24
1.8.1 Rear panel ports.....	1-24
1.8.2 Internal connectors.....	1-25
1.9 Software support.....	1-30
1.9.1 Installing an operating system.....	1-30
1.9.2 Support DVD information.....	1-30

BIOS information

2.1	Managing and updating your BIOS	2-1
2.1.1	ASUS Update utility	2-1
2.1.2	ASUS EZ Flash 2	2-2
2.1.3	ASUS CrashFree BIOS 3 utility	2-3
2.1.4	ASUS BIOS Updater.....	2-4
2.2	BIOS setup program	2-6
2.3	Main menu	2-10
2.3.1	System Language [English]	2-10
2.3.2	System Date [Day xx/xx/xxxx].....	2-10
2.3.3	System Time [xx:xx:xx]	2-10
2.3.4	Security	2-10
2.4	Ai Tweaker menu	2-12
2.4.1	Memory Frequency [Auto].....	2-13
2.4.2	iGPU Max. Frequency [Auto]	2-13
2.4.3	DRAM Timing Control	2-13
2.4.4	CPU Power Management	2-13
2.5	Advanced menu	2-15
2.5.1	CPU Configuration	2-15
2.5.2	PCH Configuration	2-18
2.5.3	SATA Configuration	2-19
2.5.4	System Agent Configuration	2-19
2.5.5	USB Configuration	2-20
2.5.6	Onboard Devices Configuration	2-21
2.5.7	APM	2-22
2.5.8	Network Stack	2-22
2.6	Monitor menu	2-23
2.6.1	CPU Temperature / MB Temperature [xxx°C/xxx°F].....	2-23
2.6.2	CPU / Chassis Fan Speed [xxxx RPM] or [Ignore] / [N/A]	2-23
2.6.3	CPU Voltage, 3.3V Voltage, 5V Voltage, 12V Voltage	2-24
2.6.4	CPU Q-Fan Control [Enabled]	2-24
2.6.5	Chassis Q-Fan Control [Enabled]	2-24
2.7	Boot menu	2-26
2.7.1	Fast Boot [Enabled]	2-27
2.7.2	Full Screen Logo [Enabled].....	2-27
2.7.3	Bootup NumLock State [On]	2-28

2.7.4	Wait for 'F1' If Error [Enabled].....	2-28
2.7.5	Option ROM Messages [Force BIOS].....	2-28
2.7.6	INT19 Trap Response [Postponed].....	2-28
2.7.7	Setup Mode [EZ Mode].....	2-28
2.7.8	CSM (Compatibility Support Module).....	2-29
2.7.9	Secure Boot.....	2-30
2.7.10	Boot Option Priorities.....	2-33
2.7.11	Boot Override.....	2-33
2.8	Tools menu.....	2-33
2.8.1	ASUS EZ Flash 2 Utility.....	2-33
2.8.2	ASUS SPD Information.....	2-33
2.8.3	ASUS O.C. Profile.....	2-34
2.9	Exit menu.....	2-35
Appendices		
	Notices.....	A-1
	ASUS contact information.....	A-3

Safety information

Electrical safety

- To prevent electrical shock hazard, disconnect the power cable from the electrical outlet before relocating the system.
- When adding or removing devices to or from the system, ensure that the power cables for the devices are unplugged before the signal cables are connected. If possible, disconnect all power cables from the existing system before you add a device.
- Before connecting or removing signal cables from the motherboard, ensure that all power cables are unplugged.
- Seek professional assistance before using an adapter or extension cord. These devices could interrupt the grounding circuit.
- Ensure that your power supply is set to the correct voltage in your area. If you are not sure about the voltage of the electrical outlet you are using, contact your local power company.
- If the power supply is broken, do not try to fix it by yourself. Contact a qualified service technician or your retailer.

Operation safety

- Before installing the motherboard and adding devices on it, carefully read all the manuals that came with the package.
- Before using the product, ensure all cables are correctly connected and the power cables are not damaged. If you detect any damage, contact your dealer immediately.
- To avoid short circuits, keep paper clips, screws, and staples away from connectors, slots, sockets and circuitry.
- Avoid dust, humidity, and temperature extremes. Do not place the product in any area where it may become wet.
- Place the product on a stable surface.
- If you encounter technical problems with the product, contact a qualified service technician or your retailer.

About this guide

This user guide contains the information you need when installing and configuring the motherboard.

How this guide is organized

This guide contains the following parts:

- **Chapter 1: Product introduction**

This chapter describes the features of the motherboard and the new technology it supports.

- **Chapter 2: BIOS information**

This chapter tells how to change system settings through the BIOS Setup menus. Detailed descriptions of the BIOS parameters are also provided.

Where to find more information

Refer to the following sources for additional information and for product and software updates.

1. **ASUS websites**

The ASUS website provides updated information on ASUS hardware and software products. Refer to the ASUS contact information.

2. **Optional documentation**

Your product package may include optional documentation, such as warranty flyers, that may have been added by your dealer. These documents are not part of the standard package.

Conventions used in this guide

To ensure that you perform certain tasks properly, take note of the following symbols used throughout this manual.



DANGER/WARNING: Information to prevent injury to yourself when trying to complete a task.



CAUTION: Information to prevent damage to the components when trying to complete a task.



IMPORTANT: Instructions that you **MUST** follow to complete a task.



NOTE: Tips and additional information to help you complete a task.

Typography

Bold text

Indicates a menu or an item to select.

Italics

Used to emphasize a word or a phrase.

<Key>

Keys enclosed in the less-than and greater-than sign means that you must press the enclosed key.

Example: <Enter> means that you must press the Enter or Return key.

<Key1> + <Key2> + <Key3>

If you must press two or more keys simultaneously, the key names are linked with a plus sign (+).

H61M-K specifications summary

CPU	LGA1155 socket for Intel® 3rd/2nd Generation Core™ i7, Core™ i5, Core™ i3, Pentium®, and Celeron® processors Supports Intel® 22nm/32nm CPU Supports Intel® Turbo Boost Technology 2.0 <ul style="list-style-type: none">• Up to 77W Thermal Design Power support.• The Intel® Turbo Boost Technology 2.0 support depends on the CPU types.• Refer to www.asus.com for Intel® CPU support list.
Chipset	Intel® H61 Express Chipset
Memory	2 x DIMMs, max. 16GB, DDR3 1600 / 1333 / 1066 MHz, non-ECC, unbuffered memory Dual-channel memory architecture <ul style="list-style-type: none">• Refer to www.asus.com for the latest Memory QVL (Qualified Vendors List).• When you install a total memory of 4GB capacity or more, Windows® 32-bit operating system may only recognize less than 3GB. We recommend a maximum of 3GB system memory if you are using a Windows® 32-bit operating system.
Expansion slots	1 x PCI Express 3.0*/2.0 x16 slot 2 x PCI Express 2.0 x1 slots <ul style="list-style-type: none">• PCIe 3.0 speed is supported by Intel® 3rd generation Core™ processors.
VGA Output	DVI-D with Max. Resolution: 1920x1200@60Hz D-SUB with Max. Resolution: 2048x1536@75Hz Max. UMA Memory: 1024MB
Storage	Intel® H61 Express Chipset: <ul style="list-style-type: none">- 4 x Serial ATA 3 Gb/s connectors
LAN	Realtek® 8111F PCIe Gigabit LAN controller
Audio	Realtek® ALC887 8-channel High Definition Audio CODEC <ul style="list-style-type: none">• Use a chassis with HD audio module in the front panel to support an 8-channel audio output.
USB	Intel® H61 Express Chipset: <ul style="list-style-type: none">- 8 x USB 2.0/1.1 ports (4 ports at the mid-board, 4 ports at the back panel)

(continued on the next page)

H61M-K specifications summary

ASUS unique features	ASUS Anti-Surge Protection ASUS UEFI BIOS (EZ Mode) ASUS MyLogo 2 ASUS EZ-Flash 2 ASUS Fan Xpert ASUS AI Charger ASUS Crash Free BIOS3 ASUS AI Suite II ASUS Network iControl™ ASUS Webstorage • The Network iControl feature does not support Windows® XP/Vista operating systems.
Rear panel ports	1 x PS/2 keyboard port (purple) 1 x PS/2 mouse port (green) 1 x DVI-D 1 x D-Sub 4 x USB 2.0/1.1 ports 1 x LAN (RJ-45) port 3 x Audio jacks
Internal connectors/ jumpers	2 x USB 2.0/1.1 connectors support additional 4 USB 2.0/1.1 ports 4 x SATA 3 Gb/s connectors 1 x 4-pin CPU fan connector 1 x 4-pin chassis fan connector 1 x Front panel audio connector 1 x System panel connector 1 x Speaker connector 1 x 24-pin ATX power connector 1 x 4-pin ATX 12V power connector 1 x Clear CMOS jumper

(continued on the next page)

H61M-K specifications summary



BIOS features	64 Mb Flash ROM, UEFI BIOS, PnP, DMI v2.0, WfM 2.0, ACPI v2.0a, SM BIOS v2.7, SLP 3.0, EUP-ready, Multi-language BIOS, ASUS EZ Flash 2, ASUS CrashFree BIOS 3, F12 PrintScreen function, F3 Shortcut function, and ASUS DRAM SPD (Serial Presence Detect) memory information
Manageability	WfM 2.0, DMI v2.0, WOR by PME, PXE
Support DVD	Drivers ASUS utilities ASUS Update Anti-virus software (OEM version)
Form factor	ATX form factor: 8.9 in x 6.9 in (22.6 cm x 17.5 cm)



Specifications are subject to change without notice.

Package contents

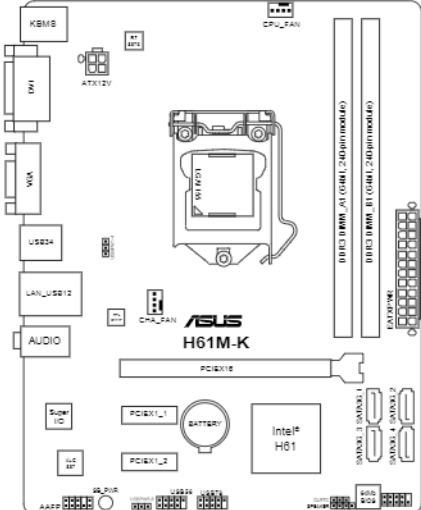
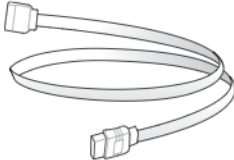
Check your motherboard package for the following items.

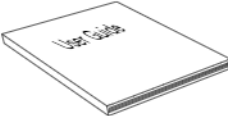
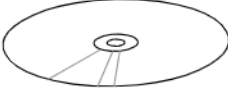
		
<p>ASUS H61M-K motherboard</p>	<p>2 x Serial ATA 3 Gb/s cables</p>	
		
<p>1 x I/O Shield</p>	<p>User Guide</p>	<p>Support DVD</p>



- If any of the above items is damaged or missing, contact your retailer.
- The illustrations above are for reference only. Actual product specifications may vary with different models.

Product introduction

1

1.1 Special features

1.1.1 Product highlights

LGA1155 socket for Intel® 3rd/2nd Generation Core™ i7, Core™ i5, Core™ i3, Pentium®, and Celeron® processors

This motherboard supports the Intel® 3rd/2nd generation Core™ i7, Core™ i5, Core™ i3, Pentium®, and Celeron® processors in the LGA1155 package, with memory and PCI Express controllers integrated to support onboard graphics out with dedicated chipsets, 2-channel (2 DIMMs) DDR3 memory, and 16 PCI Express 3.0/2.0 lanes. This provides great graphics performance. Intel® 3rd/2nd generation Core™ i7, Core™ i5, Core™ i3, Pentium®, and Celeron® processors are among the most powerful and energy efficient CPUs in the world.

Intel® H61 Express Chipset

The Intel® H61 Express Chipset is the latest single-chipset design to support the new 1155 socket Intel® 3rd/2nd Generation Core™ i7, Core™ i5, Core™ i3, Pentium®, and Celeron® processors. It provides improved performance by utilizing serial point-to-point links, which allows increased bandwidth and stability.

Dual-Channel DDR3 1600 / 1333 / 1066 MHz support

The motherboard supports DDR3 memory that features data transfer rates of 1600 / 1333 / 1066 MHz to meet the higher bandwidth requirements of the latest 3D graphics, multimedia, and Internet applications. The dual-channel DDR3 architecture enlarges the bandwidth of your system memory to boost system performance.

PCI Express® 3.0

PCI Express® 3.0 (PCIe 3.0) is the latest PCI Express bus standard with improved encoding schemes that provide twice the performance of the current PCIe 2.0. The total bandwidth for a x16 link reaches a maximum of 32Gb/s, double the 20 Gb/s of PCIe 2.0 (in x16 mode). As such, PCIe 3.0 provides users an unprecedented data speeds, combined with the convenience and seamless transition offered by complete backward compatibility with PCIe 1.0 and PCIe 2.0 devices. PCIe 3.0 will become a must-have feature for users who wish to improve and optimize graphic performance, as well as have the latest technology available to them.

* PCI 3.0 speed is supported by Intel® 3rd generation Core™ processors.

Intel® Smart Connect Technology

Your computer can receive fresh updates for selected applications, even when the system is in sleep mode. This means less time waiting for applications to update and sync with the cloud, leading to a more efficient computing experience.

Intel® Rapid Start Technology

Intel® Rapid Start Technology allows your system to receive updates for your web applications in real-time even when your system is in sleep mode, saving wait time and power usage.

8-channel high definition audio

The onboard 8-channel HD audio (High Definition Audio, previously codenamed Azalia) CODEC enables high-quality 192KHz/24-bit audio output and jack-detect feature that automatically detects and identifies what types of peripherals are plugged into the audio I/O jacks and notifies users of inappropriate connection, which means there will be no more confusion of Line-in, Line-out, and Mic jacks.

* **Use a chassis with HD audio module in the front panel to support an 8-channel audio output.**

Gigabit LAN solution

The onboard LAN controller is a highly integrated Gb LAN controller. It is enhanced with an ACPI management function to provide efficient power management for advanced operating systems.

1.1.2 ASUS Exclusive Features

ASUS UEFI BIOS (EZ Mode)

ASUS UEFI BIOS, a UEFI compliant architecture, offers the first mouse-controlled intuitive graphical BIOS interface that goes beyond the traditional keyboard-only BIOS controls, providing you with more flexibility, convenience, and easy to navigate EFI BIOS than the traditional BIOS versions. It offers you with dual selectable modes and native support for hard drives larger than 2.2 TB.

ASUS UEFI BIOS includes the following new features:

- F12 BIOS snapshot hotkey
- F3 Shortcut for most accessed information
- ASUS DRAM SPD (Serial Presence Detect) information detecting faulty DIMMs, and helping with difficult POST situations.

Network iControl

Network iControl is an intuitive one-step network control center that makes it easier for you to manage your bandwidth and allows you to set, monitor, and schedule the bandwidth priorities for your network programs. It allows you to automatically connect to a PPPoE network for a more convenient online experience.

* **The ASUS Network iControl feature does not support Windows® XP/Vista operating systems.**

Ai Charger

Ai Charger is ASUS fast-charging software that supports iPod, iPhone, and iPad.

* **Check your USB mobile device if it fully supports the BC 1.1 function.**

** **The actual charging speed may vary with your USB device's conditions.**

*** **Ai Charger is only supported when you set the USB device wake-up jumpers to +5VSB. See section 1.7 Jumpers for details.**

AI Suite II

With its user-friendly interface, ASUS AI Suite II integrates several ASUS utilities and allows you to launch and operate these utilities simultaneously. It allows you to supervise fan speed control, and voltage and sensor readings. This all-in-one software offers diverse and ease to use functions, with no need to switch back and forth between different utilities.

ASUS Anti-Surge Protection

This special design protects expensive devices and the motherboard from damage caused by power surges from switching power supply unit (PSU).

ASUS Fan Xpert

ASUS Fan Xpert intelligently allows you to adjust the CPU fan and chassis fan speeds according to different ambient temperatures caused by different climate conditions in different geographic regions and your PC's loading. The built-in variety of useful profiles offer flexible controls of fan speed to achieve a quiet and cool environment.

ASUS MyLogo2™

Turn your favorite photos into 256-color boot logos to personalize your system.

ASUS CrashFree BIOS 3

ASUS CrashFree BIOS 3 is an auto-recovery tool that allows you to restore a corrupted BIOS file using the bundled support DVD or a USB flash disk that contains the BIOS file.

ASUS EZ Flash 2

ASUS EZ Flash 2 is a user-friendly utility that allows you to update the BIOS without using a bootable floppy disk or an OS-based utility.

C.P.R. (CPU Parameter Recall)

The BIOS C.P.R. feature automatically restores the CPU default settings when the system hangs due to overclocking failure. C.P.R. eliminates the need to open the system chassis and clear the RTC data. Simply shut down and reboot the system, and the BIOS automatically restores the CPU parameters to their default settings.

ErP ready

The motherboard is European Union's Energy-related Products (ErP) ready, and ErP requires products to meet certain energy efficiency requirements with regard to energy consumptions. This is in line with ASUS vision of creating environment-friendly and energy-efficient products through product design and innovation to reduce carbon footprint of the product and thus mitigate environmental impacts.

1.2 Before you proceed

Take note of the following precautions before you install motherboard components or change any motherboard settings.



- Unplug the power cord from the wall socket before touching any component.
- Before handling components, use a grounded wrist strap or touch a safely grounded object or a metal object, such as the power supply case, to avoid damaging them due to static electricity.
- Hold components by the edges to avoid touching the ICs on them.
- Whenever you uninstall any component, place it on a grounded antistatic pad or in the bag that came with the component.
- Before you install or remove any component, switch off the ATX power supply and detach its power cord. Failure to do so may cause severe damage to the motherboard, peripherals, or components.

Standby Power LED

The motherboard comes with a standby power LED that lights up to indicate that the system is ON, in sleep mode, or in soft-off mode. This is a reminder that you should shut down the system and unplug the power cable before removing or plugging in any motherboard component. The illustration below shows the location of the onboard LED.

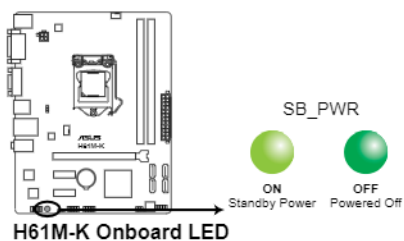

1.3 Motherboard overview

1.3.1 Placement direction

When installing the motherboard, ensure that you place it into the chassis in the correct orientation. The edge with external ports goes to the rear part of the chassis as indicated in the image below.

1.3.2 Screw holes

Place six screws into the holes indicated by circles to secure the motherboard to the chassis.



DO NOT overtighten the screws! Doing so can damage the motherboard.

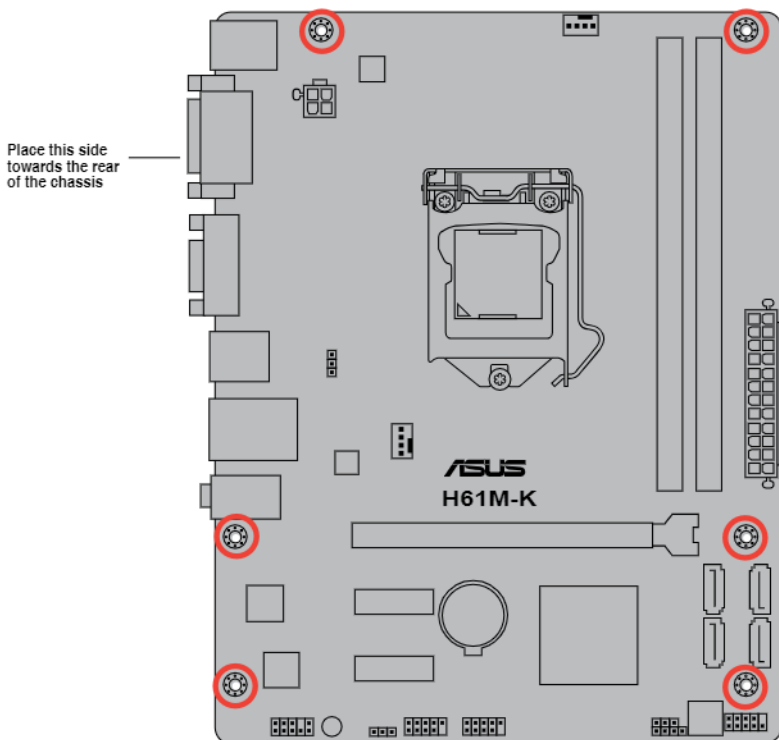

1.3.3 Motherboard layout

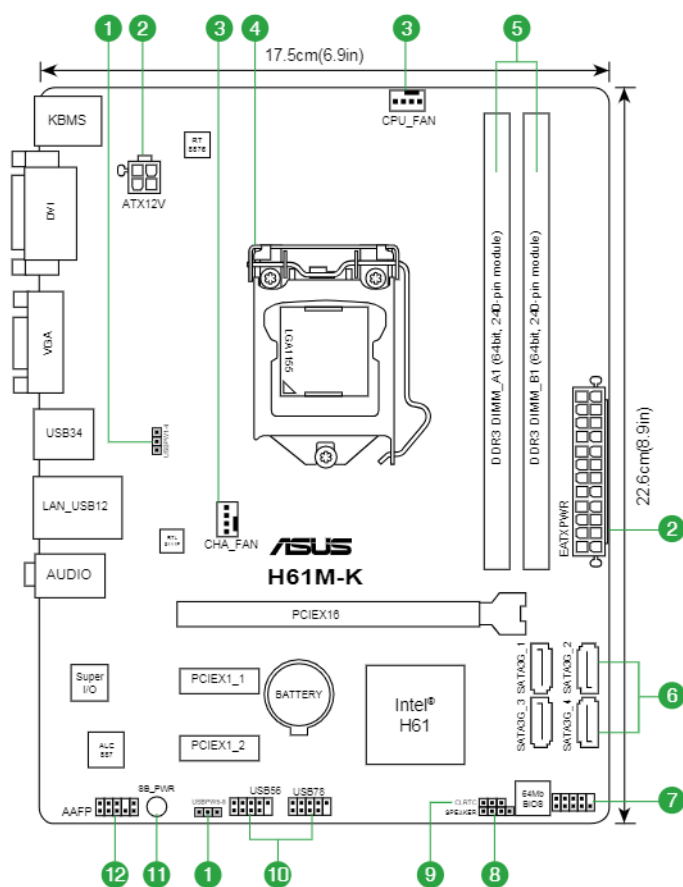

1.3.4 Layout contents

Connectors/Jumpers/Slots/LED	Page
1. USB device wake-up (3-pin PS2_USBPW1~4; USBPW5~8)	1-27
2. ATX power connectors (24-pin EATXPWR, 4-pin ATX12V)	1-26
3. CPU and chassis fan connectors (4-pin CPU_FAN, 4-pin CHA_FAN)	1-28
4. Intel® LGA1155 CPU socket	1-7
5. DDR3 DIMM slots	1-12
6. Intel® H61 Serial ATA 3.0Gb/s connectors (7-pin SATA3G_1/2/3/4)	1-27
7. System panel connector (10-1 pin F_PANEL)	1-29
8. Speaker connector (4-pin SPEAKER)	1-29
9. Clear RTC RAM (3-pin CLRTC)	1-28
10. USB 2.0 connectors (10-1 pin USB56, USB78)	1-29
11. Standby power LED (SB_PWR)	1-5
12. Front panel audio connector (10-1 pin AAFP)	1-25

1.4 Central Processing Unit (CPU)

The motherboard comes with a surface mount LGA1155 socket designed for the Intel® 3rd / 2nd Generation Core™ i7, i5, i3, Pentium®, and Celeron® processors.

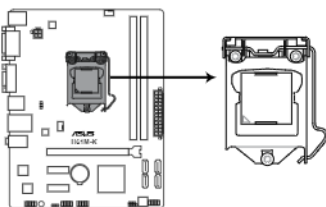

H61M-K CPU socket LGA1155



Unplug all power cables before installing the CPU.



- Upon purchase of the motherboard, ensure that the PnP cap is on the socket and the socket contacts are not bent. Contact your retailer immediately if the PnP cap is missing, or if you see any damage to the PnP cap/socket contacts/motherboard components. ASUS will shoulder the cost of repair only if the damage is shipment/transit-related.
- Keep the cap after installing the motherboard. ASUS will process Return Merchandise Authorization (RMA) requests only if the motherboard comes with the cap on the LGA1155 socket.
- The product warranty does not cover damage to the socket contacts resulting from incorrect CPU installation/removal, or misplacement/loss/incorrect removal of the PnP cap.

1.4.1 CPU installation



The LGA1156 CPU is not compatible with the LGA1155 socket. DO NOT install an LGA1156 CPU on the LGA1155 socket.

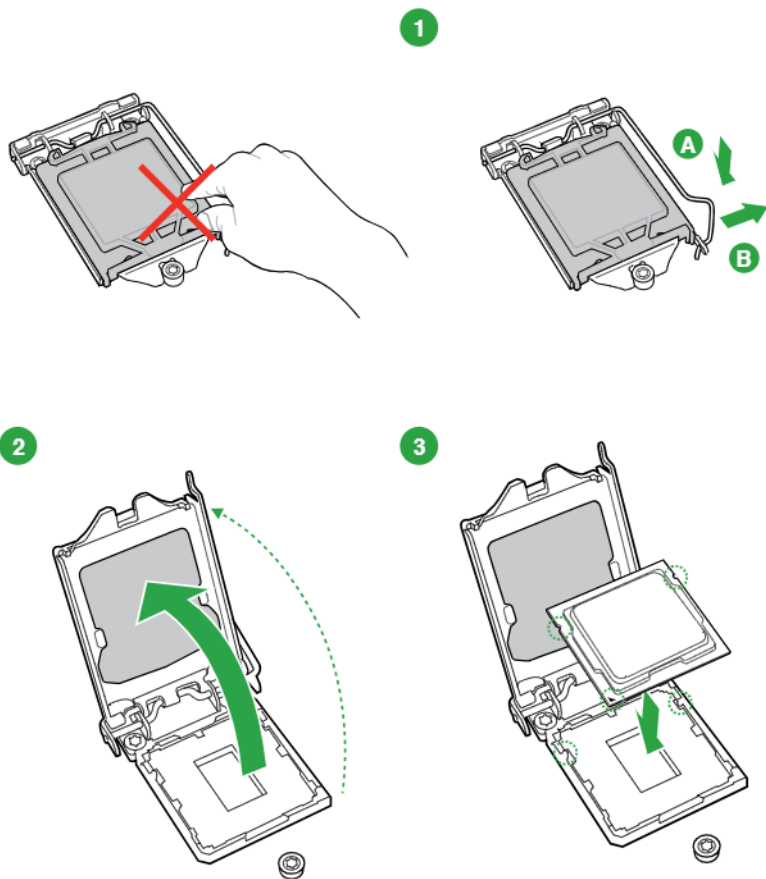

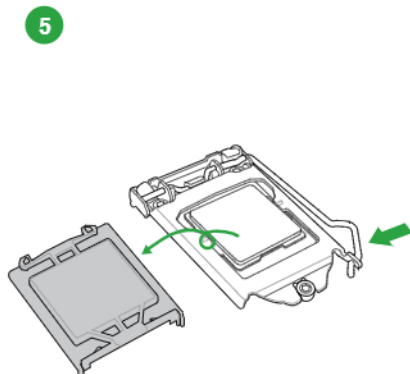
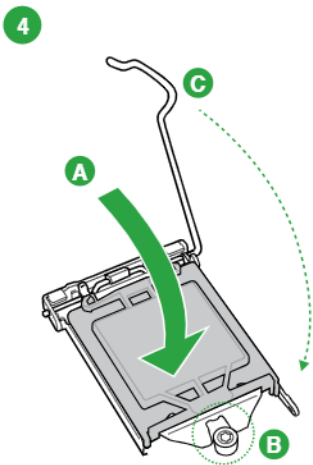

1.4.2 CPU heatsink and fan assembly installation

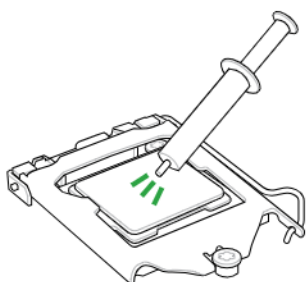

Apply the Thermal Interface Material to the CPU heatsink and CPU before you install the heatsink and fan if necessary.

To install the CPU heatsink and fan assembly

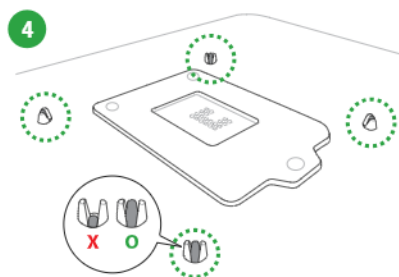
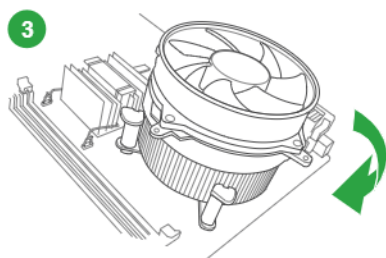
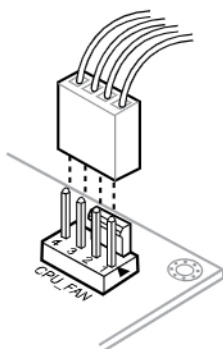
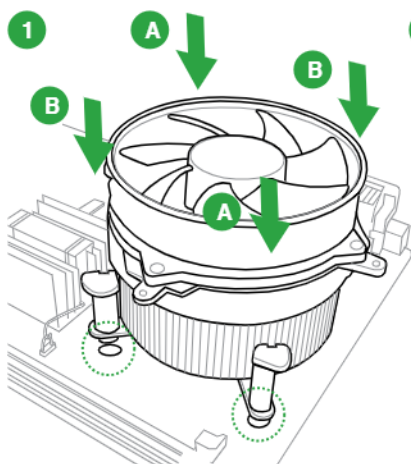

To uninstall the CPU heatsink and fan assembly

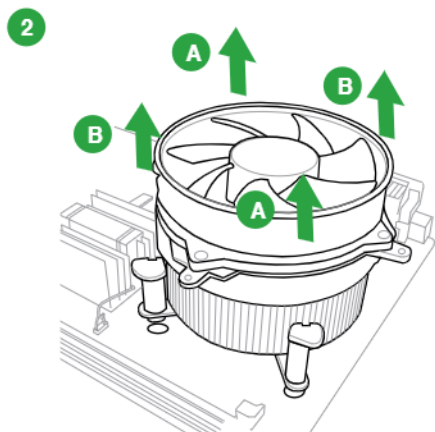
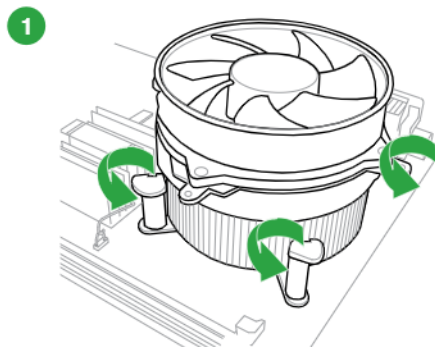

1.5 System memory

1.5.1 Overview

This motherboard comes with two Double Data Rate 3 (DDR3) Dual Inline Memory Modules (DIMM) sockets.

A DDR3 module has the same physical dimensions as a DDR2 DIMM but is notched differently to prevent installation on a DDR2 DIMM socket. DDR3 modules are developed for better performance with less power consumption.

The figure illustrates the location of the DDR3 DIMM sockets:

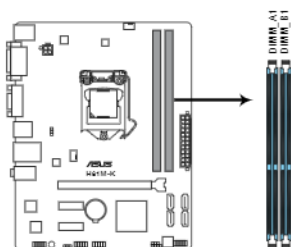

Channel	Sockets
Channel A	DIMM_A1
Channel B	DIMM_B1

H61M-K 240-pin DDR3 DIMM sockets

1.5.2 Memory configurations

You may install 1GB, 2GB, 4GB, and 8GB unbuffered non-ECC DDR3 DIMMs into the DIMM sockets.



- You may install varying memory sizes in Channel A and Channel B. The system maps the total size of the lower-sized channel for the dual-channel configuration. Any excess memory from the higher-sized channel is then mapped for single-channel operation.
- Always install DIMMs with the same CAS latency. For optimal compatibility, we recommend that you install memory modules of the same version or date code (D/C) from the same vendor. Check with the retailer to get the correct memory modules.
- Memory module with memory frequency higher than 2133 MHz and its corresponding timing or the loaded XMP Profile is not the JEDEC memory standard. The stability and compatibility of these memory modules depend on the CPU's capabilities and other installed devices.
- Due to the memory address limitation on 32-bit Windows® OS, when you install 4GB or more memory on the motherboard, the actual usable memory for the OS can be about 3GB or less. For effective use of memory, we recommend that you do any of the following:
 - Use a maximum of 3GB system memory if you are using a 32-bit Windows® OS.
 - Install a 64-bit Windows® OS when you want to install 4GB or more on the motherboard.
- This motherboard does not support DIMMs made up of 512Mb (64MB) chips or less.



- The default memory operation frequency is dependent on its Serial Presence Detect (SPD), which is the standard way of accessing information from a memory module. Under the default state, some memory modules for overclocking may operate at a lower frequency than the vendor-marked value. To operate at the vendor-marked or at a higher frequency, refer to section **2.4 AI Tweaker menu** for manual memory frequency adjustment.
- For system stability, use a more efficient memory cooling system to support a full memory load (2 DIMMs) or overclocking condition.

H61M-K Motherboard Qualified Vendors Lists (QVL)

DDR3 2666 (O.C.) MHz capability

Vendors	Part No.	Size	SS/DS	Chip Brand	Chip NO.	Timing	Voltage	DIMM socket support (Optional)	
								1 DIMM	2 DIMMs
CORSAIR	CMD16GX3M4A2666C11(XMP)	4GB	DS	-	-	11-13-13-35	1.65V	-	-
G.SKILL	F3-2666C11Q-16GTXD(XMP)	16GB(4GBx4)	DS	-	-	11-13-13-35	1.65V	-	-

DDR3-2600 MHz capability

Vendors	Part No.	Size	SS/DS	Chip Brand	Chip NO.	Timing	Voltage	DIMM socket support (Optional)	
								1 DIMM	2 DIMMs
G.SKILL	F3-2600CL10Q-16GBZMD(XMP)	16GB(4x4GB)	DS	-	-	10-12-12-31	1.65V	-	-
G.SKILL	F3-2600CL11Q-32GBZH(XMP)	32GB(8GBx4)	DS	-	-	11-13-13-35	1.65V	-	-

DDR3-2400 MHz capability

Vendors	Part No.	Size	SS/DS	Chip Brand	Chip NO.	Timing	Voltage	DIMM socket support (Optional)	
								1 DIMM	2 DIMMs
CORSAIR	CMGTX8(XMP)	8GB(2GBx4)	SS	-	-	10-12-10-27	1.65V	-	-
G.SKILL	F3-2400C10D-8GTX(XMP)	8GB(2x4GB)	SS	-	-	10-12-12-31	1.65V	-	-
G.SKILL	F3-19200CL11Q-16GBZH(XMP1.3)	16GB(4GBx4)	DS	-	-	11-11-11-31	1.65V	-	-
G.SKILL	F3-19200CL9D-4GBPiS(XMP)	4GB(2x2GB)	DS	-	-	9-11-9-28	1.65V	-	-
G.SKILL	F3-19200CL10Q-32GBZH(XMP)	8GB	DS	-	-	10-12-12-31	1.65V	-	-
GEIL	GET34GB2400C9DC(XMP)	2GB	DS	-	-	9-11-9-27	1.65V	-	-
KINGMAX	FLLE88F-C8KAA HAI8(XMP)	2GB	SS	-	-	10-11-10-30	1.8V	-	-
KINGSTON	KHX2400C11D3K4/8GX(XMP)	8GB(4GBx2)	SS	-	-	-	1.65V	-	-
KINGSTON	KHX24C11T2K2/8X(XMP)	4GB	DS	-	-	-	1.65V	-	-
ADATA	AX3U2400G4G10-DG2(XMP)	4GB	DS	-	-	10-12-12-31	1.65V	-	-
Team	TXD38G2400HC10QBK	8GB	DS	-	-	10-12-12-31	1.65V	-	-

DDR3-2250 MHz capability

Vendors	Part No.	Size	SS/DS	Chip Brand	Chip NO.	Timing	Voltage	DIMM socket support (Optional)	
								1 DIMM	2 DIMMs
Kingston	KHX2250C9D3T1K2/4GX(XMP)	4GB(2x2GB)	DS	-	-	-	1.65V	-	-

DDR3-2200 MHz capability

Vendors	Part No.	Size	SS/DS	Chip Brand	Chip No.	Timing	Voltage	DIMM socket support (optional)	
								1 DIMM	2 DIMMs
G.SKILL	F3-17600CL8D-4GBPS(XMP)	4GB(2 x 2GB)	DS	-	-	8-8-8-24	1.65V	-	-
GEIL	GET34GB2200C9DC(XMP)	2GB	DS	-	-	9-10-9-28	1.65V	-	-
GEIL	GET38GB2200C9ADC(XMP)	4GB	DS	-	-	9-11-9-28	1.65V	-	-
KINGMAX	FLKE85F-B8KJAA-FEIS(XMP)	2GB	DS	-	-	-	-	-	-
KINGMAX	FLKE85F-B8KJAA-EEIH(XMP)	4GB(2 x 2GB)	DS	-	-	-	1.5V-1.7V	-	-
KINGMAX	FLKE85F-B8KJAA-FEIH(XMP)	4GB(2 x 2GB)	DS	-	-	-	1.5V-1.7V	-	-

DDR3-2133 MHz capability

Vendors	Part No.	Size	SS/DS	Chip Brand	Chip No.	Timing	Voltage	DIMM socket support (optional)	
								1DIMM	2DIMMs
CORSAIR	CMT16G3X3M4X2133C9(XMP1.3)	16GB(4GBx4)	DS	-	-	9-11-10-27	1.50V	-	-
CORSAIR	CMT4GX3M2A2133C9(XMP)	4GB(2x2GB)	DS	-	-	9-10-9-24	1.65V	-	-
CORSAIR	CMT4GX3M2B2133C9(XMP)	4GB(2x2GB)	DS	-	-	9-10-9-27	1.50V	-	-
CORSAIR	CMT8GX3M2B2133C9(XMP)	8GB(4GBx2)	DS	-	-	9-11-9-27	1.50V	-	-
G.SKILL	F3-17000CL9Q-16GBZH(XMP1.3)	16GB(4GBx4)	DS	-	-	9-11-10-28	1.65V	-	-
G.SKILL	F3-17000CL11Q2-64GBZL(XMP)	8GB	DS	-	-	11-11-11-31	1.5V	-	-
G.SKILL	F3-2133C11Q-32GZL(XMP)	8GB	DS	-	-	11-11-11-31	1.5V	-	-
GEIL	GE34GB2133C9DC(XMP)	2GB	DS	-	-	9-9-9-28	1.65V	-	-
GEIL	GU34GB2133C9DC(XMP)	4GB(2x2GB)	DS	-	-	9-9-9-28	1.65V	-	-
KINGSTON	KHX2133C11D3K4/16GX(XMP)	16GB(4GBx4)	DS	-	-	-	1.65V	-	-
KINGSTON	KHX2133C11D3T1K2/16GX(XMP)	16GB(8GBx2)	DS	-	-	-	1.6V	-	-
KINGSTON	KHX21C11T1BK2/16X(XMP)	16GB(8GBx2)	DS	-	-	-	1.6V	-	-
KINGSTON	KHX2133C9AD3T1K2/4GX(XMP)	4GB(2x2GB)	DS	-	-	-	1.65V	-	-
KINGSTON	KHX2133C9AD3X2K2/4GX(XMP)	4GB(2x2GB)	DS	-	-	9-11-9-27	1.65V	-	-
KINGSTON	KHX2133C9AD3T1K4/8GX(XMP)	8GB(4x2GB)	DS	-	-	9-11-9-27	1.65V	-	-
KINGSTON	KHX21C11T1BK2/8X(XMP)	8GB(4GBx2)	DS	-	-	-	1.6V	-	-
KINGSTON	KHX2133C9AD3T1FK4/8GX(XMP)	8GB(4x2GB)	DS	-	-	-	1.65V	-	-
KINGSTON	KHX21C11T3K4/32X	8GB	DS	-	-	-	1.65V	-	-
ADATA	AX3U2133XC4G10-2X(XMP)	4GB	DS	-	-	10-11-11-30	1.65V	-	-
ADATA	AX3U2133XW8G10-2X(XMP)	8GB	DS	-	-	10-11-11-30	1.65V	-	-
Team	TXD34096M2133HC11-L	4GB	SS	-	-	-	1.5V	-	-
Team	TLD38G2133HC11ABK	8GB	DS	-	-	11-11-11-31	1.65V	-	-

DDR3-2000 MHz capability

Vendors	Part No.	Size	SS/DS	Chip Brand	Chip No.	Timing	Voltage	DIMM socket support (optional)	
								1DIMM	2DIMMs
Apacer	78.AAGD5.9KD(XMP)	6GB(3 x 2GB)	DS	-	-	9-9-9-27	1.65V	-	-
CORSAIR	CM24GX3M2A2000C1(XMP)	4GB(2 x 2GB)	SS	-	-	10-10-10-27	1.50V	-	-
CORSAIR	CMT6GX3M3A2000C8(XMP)	6GB(3 x 2GB)	DS	-	-	8-9-8-24	1.65V	-	-
G.SKILL	F3-16000CL9D-4GBFLS(XMP)	4GB(2 x 2GB)	DS	-	-	9-9-9-24	1.65V	-	-
G.SKILL	F3-16000CL9D-4GBTD(XMP)	4GB(2 x 2GB)	DS	-	-	9-9-9-27	1.65V	-	-
G.SKILL	F3-16000CL6T-6GBPI(XMP)	6GB(3x 2GB)	DS	-	-	6-9-6-24	1.65V	-	-
GEIL	GUP34GB2000C9DC(XMP)	4GB(2 x 2GB)	DS	-	-	9-9-9-28	1.65V	-	-
KINGSTON	KHX2000C9AD3T1K2/4GX(XMP)	4GB (2x 2GB)	DS	-	-	-	1.65V	-	-
KINGSTON	KHX2000C9AD3W1K2/4GX(XMP)	4GB (2x 2GB)	DS	-	-	-	1.65V	-	-
KINGSTON	KHX2000C9AD3W1K3/6GX(XMP)	6GB (3x 2GB)	DS	-	-	-	1.65V	-	-
KINGSTON	KHX2000C9AD3T1K3/6GX(XMP)	6GB (3x 2GB)	DS	-	-	-	1.65V	-	-

DDR3-1866 MHz capability

Vendors	Part No.	Size	SS/DS	Chip Brand	Chip No.	Timing	Voltage	DIMM socket support (optional)	
								1DIMM	2DIMMs
CORSAIR	CMT4GX3M2A1866C9(XMP)	4GB(2x2GB)	DS	-	-	9-9-9-24	1.65V	-	-
CORSAIR	CMT6GX3MA1866C9(XMP)	6GB(3x2GB)	DS	-	-	9-9-9-24	1.65V	-	-
CORSAIR	CM28GX3M2A1866C9(XMP)	8GB(2x4GB)	DS	-	-	9-10-9-27	1.50V	-	-
CRUCIAL	BLE4G3D1869DE1TX0.16FMD(XMP)	4GB	DS	-	-	9-9-9-27	1.5V	-	-
CRUCIAL	BLT4G3D1869D1TX0.13FKD(XMP)	4GB	DS	-	-	9-9-9-27	1.5V	-	-
CRUCIAL	BLT4G3D1869D2TX0B.16FMR(XMP)	4GB	DS	-	-	9-9-9-27	1.5V	-	-
G.SKILL	F3-14900CL9Q-16GBZL(XMP1.3)	16GB(4GBx4)	DS	-	-	9-10-9-28	1.5V	-	-
G.SKILL	F3-14900CL10Q2-64GBZL(XMP1.3)	64GB(8GBx8)	DS	-	-	10-11-10-30	1.5V	-	-
G.SKILL	F3-14900CL9D-8GBXL(XMP)	8GB(2x4GB)	DS	-	-	9-10-9-28	1.5V	-	-
G.SKILL	F3-14900CL9Q-8GBXL(XMP)	8GB(2GBx4)	DS	-	-	9-9-9-24	1.6V	-	-
KINGSTON	KHX1866C9D3K4/16GX(XMP)	16GB(4GBx4)	DS	-	-	-	1.65V	-	-
KINGSTON	KHX1866C11D3P1K2/8G	8GB(4GBx2)	DS	-	-	-	1.5V	-	-
KINGSTON	KHX1866C9D3K2/8GX(XMP)	8GB(4GBx2)	DS	-	-	-	1.65V	-	-
Team	TLD34G1866H9KBK	4GB	DS	-	-	9-11-9-27	1.5V	-	-
Team	TLD38G1866HC10SBK	8GB	DS	-	-	10-11-10-30	1.5V	-	-

DDR3-1800 MHz capability

Vendors	Part No.	Size	SS/DS	Chip Brand	Chip NO.	Timing	Voltage	DIMM socket support (Optional)	
								1 DIMM	2 DIMMs
Kingston	KHX18C10T3K4/32X	8GB	DS	-	-	-	1.5V	-	-

DDR3-1600 MHz capability

Vendors	Part No.	Size	SS/DS	Chip Brand	Chip NO.	Timing	Voltage	DIMM socket support (optional)	
								1DIMM	2DIMMs
APACER	4GB UNB PC3-12800 CL11	4GB	SS	APACER	AM5D6008BQOSCK	-	-	-	-
Apacer	78.B1GE3.9L10C	4GB	DS	ApacerKZZC	AM5D5908DEQOSCK	-	-	-	-
APACER	8GB UNB PC3-12800 CL11	8GB	DS	APACER	AM5D6008BQOSCK	-	-	-	-
CORSAIR	CM12GX3M6A1600C8 (XMP)	12GB (6x2GB)	DS	-	-	8-8-8-24	1.65V	-	-
CORSAIR	CMZ32GX3M4X1600C10 (XMP)	32GB (8GBx4)	DS	-	-	10-10-10-27	1.50V	-	-
CORSAIR	CMP4GX3M2A1600C8 (XMP)	4GB (2x2GB)	DS	-	-	8-8-8-24	1.65V	-	-
CORSAIR	CMP4GX3M2A1600C9 (XMP)	4GB (2x2GB)	DS	-	-	9-9-9-24	1.65V	-	-
CORSAIR	CMP4GX3M2C1600C7 (XMP)	4GB (2x2GB)	DS	-	-	7-8-7-20	1.65V	-	-
CORSAIR	CMX4GX3M2A1600C9 (XMP)	4GB (2x2GB)	DS	-	-	9-9-9-24	1.65V	-	-
CORSAIR	TR3X6G1600C8 G (XMP)	6GB (3x2GB)	DS	-	-	8-8-8-24	1.65V	-	-
CORSAIR	TR3X6G1600C8D G (XMP)	6GB (3x2GB)	DS	-	-	8-8-8-24	1.65V	-	-
CORSAIR	TR3X6G1600C9 G (XMP)	6GB (3x2GB)	DS	-	-	9-9-9-24	1.65V	-	-
CORSAIR	CMP8GX3M2A1600C9 (XMP)	8GB (2x4GB)	DS	-	-	9-9-9-24	1.65V	-	-
CORSAIR	CMZ8GX3M2A1600C7R (XMP)	8GB (2x4GB)	DS	-	-	7-8-7-20	1.50V	-	-
CORSAIR	CMX8GX3M4A1600C9 (XMP)	8GB (4x2GB)	DS	-	-	9-9-9-24	1.65V	-	-
CORSAIR	CMZ8GX3M1A1600C10 (XMP)	8GB	DS	-	-	10-10-10-27	1.50V	-	-
Crucial	BL25664BN1608.16FF (XMP)	6GB (3x2GB)	DS	-	-	-	-	-	-
G.SKILL	F3-12800CL7D-4GBRH (XMP)	4GB (2x2GB)	SS	-	-	7-7-7-24	1.6V	-	-
G.SKILL	F3-12800CL7D-4GBECO (XMP)	4GB (2x2GB)	DS	-	-	7-7-8-24	XMP1.35V	-	-
G.SKILL	F3-12800CL7D-4GBRM (XMP)	4GB (2x2GB)	DS	-	-	7-8-7-24	1.6V	-	-
G.SKILL	F3-12800CL8D-4GBRM (XMP)	4GB (2x2GB)	DS	-	-	8-8-8-24	1.60V	-	-
G.SKILL	F3-12800CL9D-4GBECO (XMP)	4GB (2x2GB)	DS	-	-	9-9-9-24	XMP1.35V	-	-
G.SKILL	F3-12800CL9D-4GBRL (XMP)	4GB (2x2GB)	DS	-	-	9-9-9-24	1.5V	-	-
G.SKILL	F3-12800CL7D-8GBRH (XMP)	8GB (2x4GB)	DS	-	-	7-8-7-24	1.6V	-	-
G.SKILL	F3-12800CL8D-8GBECO (XMP)	8GB (2x4GB)	DS	-	-	8-8-8-24	XMP1.35V	-	-
G.SKILL	F3-12800CL9D-8GBRL (XMP)	8GB (2x4GB)	DS	-	-	9-9-9-24	1.5V	-	-
G.SKILL	F3-12800CL10S-8GBXL (XMP)	8GB	DS	-	-	10-10-10-30	-	-	-
GEIL	GET316GB1600C9QC (XMP)	16GB (4x4GB)	DS	-	-	9-9-9-28	1.6V	-	-
HYNIX	HMT351U6CFR8C-PB	4GB	DS	HYNIX	H5TQ2G83CFR.PBC	-	-	-	-
KINGMAX	FLGE85F-88KJ9A.FEiS (XMP)	2GB	DS	-	-	-	-	-	-
KINGMAX	FLGE85F-88MF7.MEEH (XMP)	2GB	DS	-	-	7	-	-	-

(continued on the next page)

DDR3-1600 MHz capability

Vendors	Part No.	Size	SS/DS	Chip Brand	Chip No.	Timing	Voltage	DIMM socket support (optional)	
								1DIMM	2DIMMs
Kingston	KHX1600C9D3P1K2/4G	4GB(2x2GB)	SS	-	-	-	1.5V	-	-
Kingston	KHX1600C9D3K3/12GX(XMP)	12GB(3x4GB)	DS	-	-	9-9-9-27	1.65V	-	-
Kingston	KHX1600C9D3T1BK3/12GX(XMP)	12GB(3x4GB)	DS	-	-	9-9-9-27	1.65V	-	-
Kingston	KHX1600C9D3K4/16GX(XMP)	16GB(4GBx4)	DS	-	-	-	1.65V	-	-
Kingston	KHX1600C10D3B1K2/16G	16GB(8GBx2)	DS	-	-	-	1.5V	-	-
Kingston	KHX16C9K2/16	16GB(8GBx2)	DS	-	-	-	1.5V	-	-
Kingston	KHX1600C9AD3/2G	2GB	DS	-	-	-	1.65V	-	-
Kingston	KVR1600D3N11/2G-ES	2GB	DS	KTC	D1288JPNPDL09U	11-11-11-28	1.35V-1.5V	-	-
Kingston	KHX1600C7D3K2/4GX(XMP)	4GB(2x2GB)	DS	-	-	-	1.65V	-	-
Kingston	KHX1600C8D3K2/4GX(XMP)	4GB(2x2GB)	DS	-	-	8	1.65V	-	-
Kingston	KHX1600C8D3T1K2/4GX(XMP)	4GB(2x2GB)	DS	-	-	8	1.65V	-	-
Kingston	KHX1600C9D3K2/4GX(XMP)	4GB(2x2GB)	DS	-	-	9	1.65V	-	-
Kingston	KHX1600C9D3LK2/4GX(XMP)	4GB(2x2GB)	DS	-	-	9	XMP1.35V	-	-
Kingston	KHX1600C9D3X2K2/4GX(XMP)	4GB(2x2GB)	DS	-	-	9-9-9-27	1.65V	-	-
Kingston	KVR16N11/4	4GB	DS	Kingston	D2568GEROPGGBU	-	1.5V	-	-
Kingston	KHX1600C9D3T1K3/6GX(XMP)	6GB(3x2GB)	DS	-	-	-	1.65V	-	-
Kingston	KHX1600C9D3K3/6GX(XMP)	6GB(3x2GB)	DS	-	-	9	1.65V	-	-
Kingston	KHX1600C9D3T1BK3/6GX(XMP)	6GB(3x2GB)	DS	-	-	9-9-9-27	1.65V	-	-
Kingston	KHX1600C9D3K2/8GX(XMP)	8GB(2x4GB)	DS	-	-	-	1.65V	-	-
Kingston	KHX1600C9D3P1K2/8G	8GB(2x4GB)	DS	-	-	-	1.5V	-	-
Kingston	KHX16C10B1K2/16X(XMP)	8GB	DS	-	-	-	1.5V	-	-
Kingston	KHX16C9P1K2/16(XMP)	8GB	DS	-	-	-	1.5V	-	-
PSC	AL9F8L93B-GN2E	4GB	SS	PSC	XHP284C3G-M	-	-	-	-
PSC	ALAF8L93B-GN2E	8GB	DS	PSC	XHR425C3G-M	-	-	-	-
Transcend	4G DDR3 1600 DIMM CL11	4GB	DS	Transcend	E226V8DOR480	-	-	-	-
Transcend	8G DDR3 1600 DIMM CL11	8GB	DS	SEC 222HYKO	6MD9639W	-	-	-	-
Transcend	8G DDR3 1600 DIMM CL11	8GB	DS	Transcend	E223X8BO648S	-	-	-	-
ADATA	AD3U1600C2G11-B	2GB	SS	-	N/A	-	-	-	-
ADATA	AD3U1600W4G11-B	4GB	SS	ADATA	F209X8BR6413	-	-	-	-
ADATA	AD3U1600C4G11-B	4GB	DS	-	N/A	-	-	-	-
ADATA	AD3U1600W8G11-B	8GB	DS	ADATA	F211X8B0640A	-	-	-	-
SanMax	SMD-4G68HP-16KZ	4GB	DS	HYNIX	H5TQ2G83BFR PBC	-	-	-	-
TEAM	TED34G1600HC11BK	4GB	DS	-	-	11-11-11-28	-	-	-
TEAM	TD34G1600HC9BK(XMP)	4GB	DS	-	-	9-9-24	1.5V	-	-
Team	TED38G1600HC11BK	8GB	DS	-	-	11-11-11-28	-	-	-

DDR3-1333 MHz capability

Vendors	Part No.	Size	SS/DS	Chip Brand	Chip No.	Timing	Voltage	DIMM socket support(optional)	
								1DIMM	2DIMMs
A-DATA	AD3U1333C2G9	2GB	SS	A-DATA	3CCD-1509HNA1126L	-	-	-	-
A-DATA	AX3U1333C2G9-BP	2GB	SS	-	-	-	-	-	-
Apacer	78.A1G6C9L1	2GB	DS	Apacer	AM5D5808DEWSBG	-	-	-	-
Apacer	78.A1G6C9L1	2GB	DS	Apacer	AM5D5808FEQSBG	9	-	-	-
Apacer	AU02GFA33C9NBGC	2GB	DS	Apacer	AM5D5808APOSBG	-	-	-	-
Apacer	78.B1GDE9L10C	4GB	DS	Apacer	AM5D5908CEHSBG	-	-	-	-
Corsair	TR3X6G1333C9 G	6GB (3x2GB)	SS	-	-	9-9-9-24	1.50V	-	-
Corsair	CMD24GX3M6A1333C9 (XMP)	24GB (6x4GB)	DS	-	-	9-9-9-24	1.60V	-	-
Corsair	TW3X4G1333C9D G	4GB (2x2GB)	DS	-	-	9-9-9-24	1.50V	-	-
Corsair	CM3X4GA1333C9N2	4GB	DS	Corsair	256MBDCJGELC0401136	9-9-9-24	-	-	-
Corsair	CMX4GX3M1A1333C9	4GB	DS	-	-	9-9-9-24	1.50V	-	-
Corsair	CMD8GX3M4A1333C7	8GB (4x2GB)	DS	-	-	7-7-7-20	1.60V	-	-
Crucial	CT25664BA1339.16FF	2GB	DS	Micron	9KF27D9KPT	9	-	-	-
Crucial	CT25672BA1339.18FF	2GB	DS	Micron	91F22D9KPT(ECC)	9	-	-	-
Crucial	BL25664BN1337.16FF (XMP)	6GB (3x2GB)	DS	-	-	7-7-7-24	1.65V	-	-
ELPIDA	EBJ21UE8EDF0-DJ-F	2GB	DS	ELPIDA	J1108EDSE-DJ-F	-	1.35V (low voltage)	-	-
G.SKILL	F3-10666CL8D-4GBECO (XMP)	4GB (2x2GB)	DS	-	-	8-8-8-8-24	XMP 1.35V	-	-
G.SKILL	F3-10666CL7D-8GBRH (XMP)	8GB (2x4GB)	DS	-	-	7-7-7-21	1.5V	-	-
GEIL	GG34GB1333C9DC	4GB (2x2GB)	DS	GEIL	GL1L128M88BA12N	9-9-9-24	1.3V (low voltage)	-	-
GEIL	GV34GB1333C9DC	4GB (2x2GB)	DS	-	-	9-9-9-24	1.5V	-	-
GEIL	GVP34GB1333C7DC	4GB (2x2GB)	DS	-	-	7-7-7-24	1.5V	-	-
Hynix	HMT325U6BFR8C-H9	2GB	SS	Hynix	H5TQ2G83BFRH9C	-	-	-	-
Hynix	HMT125U6TFR8A-H9	2GB	DS	Hynix	H5TC1G83TFRH9A	-	1.35V (low voltage)	-	-
Hynix	HMT351U6BFR8C-H9	4GB	DS	Hynix	H5TQ2G83BFRH9C	-	-	-	-
Kingmax	FLFE85F-C8K9 CAES	2GB	SS	Kingmax	KFC8FMFXF-DXX-15A	-	-	-	-
Kingmax	FLFE85F-C8KL9 NAES	2GB	SS	Kingmax	KFC8FNLXF-DXX-15A	-	-	-	-
Kingmax	FLFE85F-C8KM9 NAES	2GB	SS	Kingmax	KFC8FNMXF-BXX-15A	-	-	-	-
Kingmax	FLFE85F-B8KL9 NEES	2GB	DS	Kingmax	KKB8FNWBFGNX-26A	-	-	-	-
Kingmax	FLFF65F-C8KL9 NEES	4GB	DS	Kingmax	KFC8FNLXF-DXX-15A	-	-	-	-
Kingmax	FLFF65F-C8KM9 NEES	4GB	DS	Kingmax	KFC8FNMXF-BXX-15A	-	-	-	-
Kingston	KVR1333D3N9/2G	2GB	SS	Hynix	H5TQ2G83AFRH9C	9	-	-	-
Kingston	KVR1333D3S8N9/2G	2GB	SS	Micron	IID77 D9LJK	-	1.5V	-	-
Kingston	KVR1333D3S8N9/2G-SP	2GB	SS	ELPIDA	J2108BCSE-DJ-F	-	1.5V	-	-
Kingston	KVR1333D3N9/2G	2GB	DS	ELPIDA	J1108BF8G-DJ-F	9	1.5V	-	-
Kingston	KVR1333D3N9/2G-SP	2GB	DS	KTC	D128JEMFNGD9U	-	1.5V	-	-
Kingston	KVR1333D3N9/2G-SP	2GB	DS	Kingston	D128JPSFPGD9U	-	1.5V	-	-
Kingston	KHX1333C7D3K2/4GX (XMP)	4GB (2x2GB)	DS	-	-	7	1.65V	-	-
Kingston	KHX1333C9D3UK2/4GX (XMP)	4GB (2x2GB)	DS	-	-	9	XMP1.25V	-	-
Kingston	KVR1333D3N9/4G	4GB	DS	ELPIDA	J2108BCSE-DJ-F	-	1.5V	-	-
Kingston	KVR1333D3N9/4G	4GB	DS	KTC	D2568JENCNGD9U	-	1.5V	-	-
Kingston	KVR1333D3N9/4G	4GB	DS	Hynix	H5TQ2G83AFR	-	-	-	-
Kingston	KVR1333D3N9/4G-SP	4GB	DS	Kingston	D2568JENCNGD9U	-	1.5V	-	-

DDR3-1333 MHz capability

Vendors	Part No.	Size	SS/DS	Chip Brand	Chip No.	Timing	Voltage	DIMM socket support (Optional)	
								1 DIMM	2 DIMMs
Micron	MT8JTF25664AZ-1G4D1	2GB	SS	Micron	QJD12D9L GK	-	-	-	-
Micron	MT8JTF25664AZ-1G4M1	2GB	SS	MICRON	IJM22 D9PFJ	-	-	-	-
Micron	MT18JSF25672AZ-1G4F1	2GB	DS	Micron	91F22D9KPT(ECC)	9	-	-	-
Micron	MT16JTF51264AZ-1G4D1	4GB	DS	Micron	OLD22D9L GK	-	-	-	-
NANYA	NT4GC64B8HG0NF-CG	4GB	DS	NANYA	NT5CB256M8GN-CG	-	-	-	-
PSC	AL8F8G73F-DJ2	2GB	DS	PSC	A3P1GF3FGF	-	-	-	-
Samsung	M378B5773DH0-CH9	2GB	SS	Samsung	K4B2G0846D	-	-	-	-
Samsung	M378B5673FH0-CH9	2GB	DS	Samsung	K4B1G0846F	-	-	-	-
Samsung	M391B5673DZ1-CH9	2GB	DS	Samsung	K4B1G0846D-HCH9(ECC)	-	-	-	-
Samsung	M378B5273CH0-CH9	4GB	DS	Samsung	K4B2G0846C	-	-	-	-
Samsung	M378B1G73AH0-CH9	8GB	DS	Samsung	K4B4G0846A-HCH9	-	-	-	-
Super Talent	W1333UB2GS	2GB	DS	Samsung	K4B1G0846F	9	-	-	-
Super Talent	W1333UB4GS	4GB	DS	Samsung	K4B2G0846C	-	-	-	-
Super Talent	W1333UX6GM	6GB (3x2GB)	DS	Micron	0BF27D9KPT	9-9-9-24	1.5V	-	-
Transcend	JM1333KLN-2G	2GB	SS	HYNIX	H5TQ2G832RH9C	-	-	-	-
Transcend	8G DDR3 1333 DIMM CL9	8GB	DS	Transcend	E207X8B0643Y	-	-	-	-
Transcend	8G DDR3 1333 DIMM CL9	8GB	DS	-	N/A	-	-	-	-
KINGSTEK	KSTD3PC-10600	2GB	SS	MICRON	PE911-125E	-	-	-	-
TEAM	TED34G1333HC9BK	4GB	DS	-	-	9-9-9-24	-	-	-
TEAM	TED38G1333HC9BK	8GB	DS	-	-	9-9-9-24	-	-	-

DDR3 1066 MHz capability

Vendors	Part No.	Size	SS/DS	Chip Brand	Chip NO.	Timing	Voltage	DIMM socket support (Optional)	
								1 DIMM	2 DIMMs
Crucial	CT25664BA1067.16FF	2GB	DS	Micron	9HF22D9KPT	7	-	-	-
Elpida	EBJ21UE8EDF0-AE-F	2GB	DS	Elpida	J1108EDSE-DJ-F	-	1.35V(low voltage)	-	-
Kingston	KVR1066D3N7/2G	2GB	DS	Elpida	J1108BFSE-DJ-F	-	1.5V	-	-
Kingston	KVR1066D3N7/4G	4GB	DS	Hynix	H5TQ2G83AFR-	7	1.5V	-	-



SS: Single-sided / DS: Double-sided

DIMM support:

- **1 DIMM:** Supports one module inserted into either slot as single-channel memory configuration.
- **2 DIMMs:** Supports one pair of modules inserted into both the blue slots as one pair of dual-channel memory configuration.



Visit the ASUS website at www.asus.com for the latest QVL.

1.5.3 Installing a DIMM

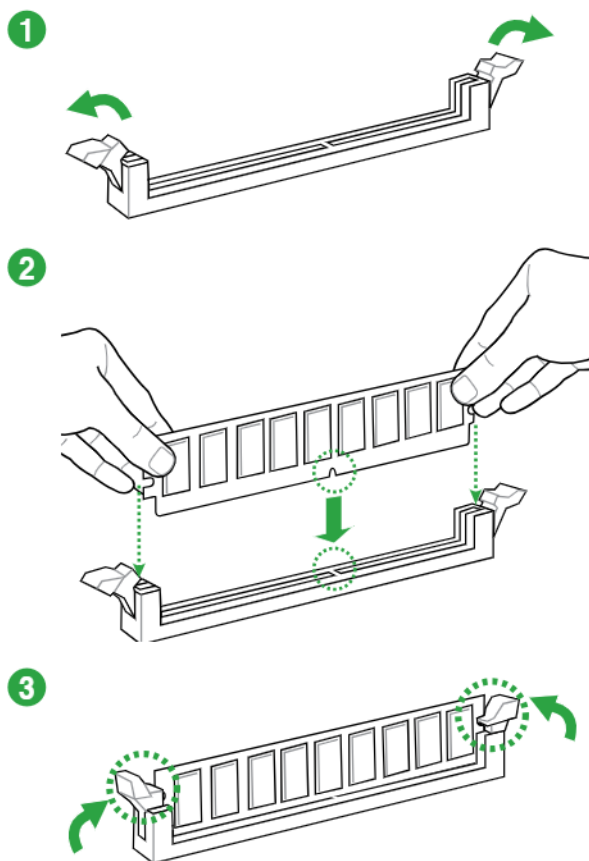

To remove a DIMM

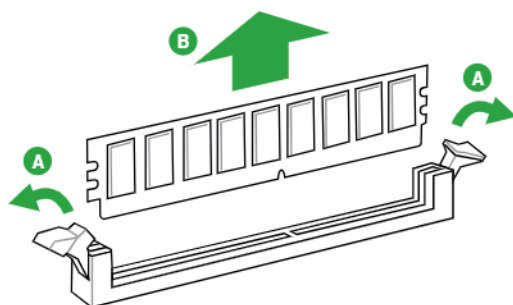

1.6 Expansion slots

In the future, you may need to install expansion cards. The following sub-sections describe the slots and the expansion cards that they support.



Unplug the power cord before adding or removing expansion cards. Failure to do so may cause you physical injury and damage motherboard components.

1.6.1 Installing an expansion card

To install an expansion card:

1. Before installing the expansion card, read the documentation that came with it and make the necessary hardware settings for the card.
2. Remove the system unit cover (if your motherboard is already installed in a chassis).
3. Remove the bracket opposite the slot that you intend to use. Keep the screw for later use.
4. Align the card connector with the slot and press firmly until the card is completely seated on the slot.
5. Secure the card to the chassis with the screw you removed earlier.
6. Replace the system cover.

1.6.2 Configuring an expansion card

After installing the expansion card, configure it by adjusting the software settings.

1. Turn on the system and change the necessary BIOS settings, if any. See Chapter 2 for information on BIOS setup.
2. Assign an IRQ to the card.
3. Install the software drivers for the expansion card.



When using PCI cards on shared slots, ensure that the drivers support "Share IRQ" or that the cards do not need IRQ assignments. Otherwise, conflicts will arise between the two PCI groups, making the system unstable and the card inoperable.

1.6.3 PCI Express 2.0 x1 slot

This motherboard supports PCI Express 2.0 x1 network cards, SCSI cards, and other cards that comply with the PCI Express specifications.

1.6.4 PCI Express 3.0/2.0 x16 slot

This motherboard has a PCI Express 3.0/2.0 x16 slot that supports PCI Express 3.0/2.0 x16 graphic cards complying with the PCI Express specifications.



PCIe 3.0 speed is supported by Intel® 3rd generation Core™ processors.

IRQ assignments for this motherboard

	A	B	C	D	E	F	G	H
PCIEx16	shared	-	-	-	-	-	-	-
PCIEx1_1	-	-	-	shared	-	-	-	-
PCIEx1_2	shared	-	-	-	-	-	-	-
Realtek 8111F controller	-	shared	-	-	-	-	-	-
USB2.0 controller 1	-	-	-	-	-	-	-	shared
USB2.0 controller 2	-	-	-	-	-	-	-	shared
HD audio	-	-	-	-	-	-	shared	-
SATA controller 1	-	-	-	shared	-	-	-	-
SATA controller 2	-	-	-	shared	-	-	-	-

1.7 Jumpers

1. Clear RTC RAM (3-pin CLRRTC)

This jumper allows you to clear the Real Time Clock (RTC) RAM in CMOS. You can clear the CMOS memory of date, time, and system setup parameters by erasing the CMOS RTC RAM data. The onboard button cell battery powers the RAM data in CMOS, which include system setup information such as system passwords.

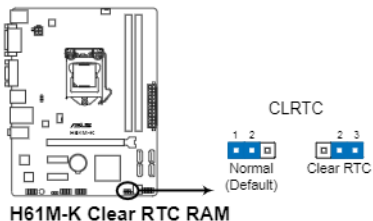

To erase the RTC RAM:

1. Turn OFF the computer and unplug the power cord.
2. Move the jumper cap from pins 1-2 (default) to pins 2-3. Keep the cap on pins 2-3 for about 5~10 seconds, then move the cap back to pins 1-2.
3. Plug the power cord and turn ON the computer.
4. Hold down the **** key during the boot process and enter BIOS setup to reenter data.



Except when clearing the RTC RAM, never remove the cap on CLRRTC jumper default position. Removing the cap will cause system boot failure!



- If the steps above do not help, remove the onboard battery and move the jumper again to clear the CMOS RTC RAM data. After clearing the CMOS, reinstall the battery.
 - You do not need to clear the RTC when the system hangs due to overclocking. For system failure due to overclocking, use the CPU Parameter Recall (C.P.R) feature. Shut down and reboot the system so the BIOS can automatically reset parameter settings to default values.
-

1.8 Connectors

1.8.1 Rear panel ports

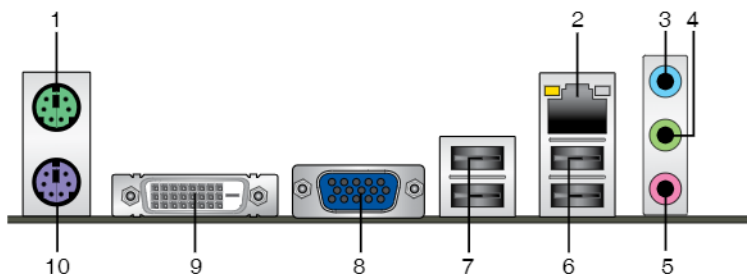

1. **PS/2 Mouse port.** This port connects to a PS/2 mouse.
2. **LAN (RJ-45) port.** This port allows Gigabit connection to a Local Area Network (LAN) through a network hub. Refer to the table below for the LAN port LED indications.

LAN port LED indications

Activity/Link LED		Speed LED	
Status	Description	Status	Description
OFF	No link	OFF	10Mbps connection
ORANGE	Linked	ORANGE	100Mbps connection
BLINKING	Data activity	GREEN	1Gbps connection

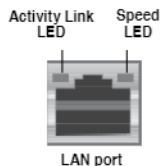

3. **Line In port (light blue).** This port connects to the tape, CD, DVD player, or other audio sources.
4. **Line Out port (lime).** This port connects to a headphone or a speaker. In the 4, 6, and 8-channel configurations, the function of this port becomes Front Speaker Out.
5. **Microphone port (pink).** This port connects to a microphone.



Refer to the audio configuration table below for the function of the audio ports in 2, 4, 6, or 8-channel configuration.

Audio 2, 4, 6, or 8-channel configuration

Port	Headset 2-channel	4-channel	6-channel	8-channel
Light Blue (Rear panel)	Line In	Rear Speaker Out	Rear Speaker Out	Rear Speaker Out
Lime (Rear panel)	Line Out	Front Speaker Out	Front Speaker Out	Front Speaker Out
Pink (Rear panel)	Mic In	Mic In	Bass/Center	Bass/Center
Lime (Front panel)	-	-	-	Side Speaker Out



To configure an 8-channel audio output:

Use a chassis with HD audio module in the front panel to support an 8-channel audio output.

- USB 2.0 ports 1 and 2.** These two 4-pin Universal Serial Bus (USB) ports are for USB 2.0/1.1 devices.
- USB 2.0 ports 3 and 4.** These two 4-pin Universal Serial Bus (USB) ports are for USB 2.0/1.1 devices.
- Video Graphics Adapter (VGA) port.** This 15-pin port is for a VGA monitor or other VGA-compatible devices.
- DVI-D port.** This port is for any DVI-D compatible device. DVI-D can't be converted to output RGB signal to CRT and isn't compatible with DVI-I
- PS/2 Keyboard port (purple).** This port is for a PS/2 keyboard.

1.8.2 Internal connectors

1. Front panel audio connector (10-1 pin AAFP)

This connector is for a chassis-mounted front panel audio I/O module that supports either HD Audio or legacy AC'97 audio standard. Connect one end of the front panel audio I/O module cable to this connector.

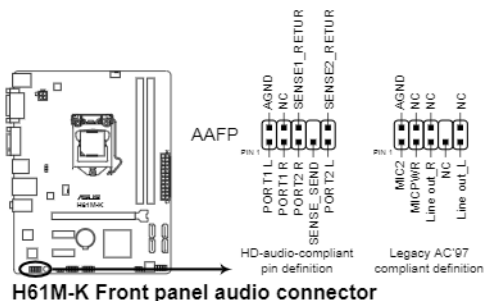

- We recommend that you connect a high-definition front panel audio module to this connector to avail of the motherboard's high-definition audio capability.
- If you want to connect a high-definition front panel audio module to this connector, set the **Front Panel Type** item in the BIOS setup to **IHD1**. If you want to connect an AC'97 front panel audio module to this connector, set the item to **AC971**. By default, this connector is set to **IHD1**. See section **2.5.6 Onboard Devices Configuration** for details.

2. ATX power connectors (24-pin EATXPWR, 4-pin ATX12V)

These connectors are for ATX power supply plugs. The power supply plugs are designed to fit these connectors in only one orientation. Find the proper orientation and push down firmly until the connectors completely fit.

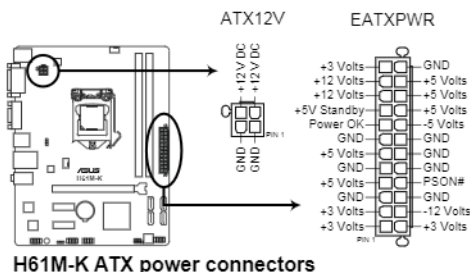

- For a fully configured system, we recommend that you use a power supply unit (PSU) that complies with ATX 12 V Specification 2.0 (or later version) and provides a minimum power of 350 W.
- DO NOT forget to connect the 4-pin ATX +12V power plug. Otherwise, the system will not boot up.
- We recommend that you use a PSU with higher power output when configuring a system with more power-consuming devices. The system may become unstable or may not boot up if the power is inadequate.
- If you are uncertain about the minimum power supply requirement for your system, refer to the Recommended Power Supply Wattage Calculator at <http://support.asus.com/PowerSupplyCalculator/PSCalculator.aspx?SLanguage=en-us> for details.

3. Intel® H61 Serial ATA 3.0Gb/s connectors (7-pin SATA3G_1~4)

These connectors connect to Serial ATA 3.0 Gb/s hard disk drives and optical drives via Serial ATA 3.0 Gb/s signal cables.

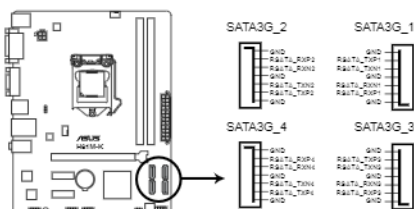

H61M-K Intel® SATA 3.0Gb/s connectors



- You must install Windows® XP Service Pack 3 or later version before using Serial ATA hard disk drives.
- Due to H61 Chipset limitation, AHCI Mode only works on Windows® Vista / Windows® 7. Please use IDE Mode on Windows® XP.
- To configure the SATA type in BIOS, click **Advanced Mode > Advanced tab > SATA Configuration > SATA Mode Selection**. See section 2.5.3 SATA Configuration for details.
- When using hot-plug and NCQ on Windows® Vista / Windows® 7, set the **SATA Mode Selection** item in the BIOS to [AHCI]. See section 2.5.3 SATA Configuration for details.

4. USB device wake-up (3-pin PS2_USBPW1~4; USBPW5~8)

Set this jumper to +5V to wake up the computer from S1 sleep mode (CPU stopped, DRAM refreshed, system running in low power mode) using the connected USB devices. Set to +5VSB to wake up from S3 and S4 sleep modes (no power to CPU, DRAM in slow refresh, power supply in reduced power mode).

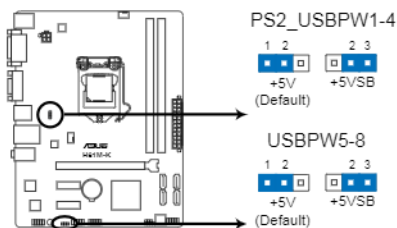

H61M-K USB Device Wake Up



- The USB device wake-up feature requires a power supply that can provide 500mA on the +5VSB lead for each USB port; otherwise, the system would not power up.
- The total current consumed must NOT exceed the power supply capability (+5VSB) whether under normal condition or in sleep mode.

5. CPU and chassis fan connectors (4-pin CPU_FAN, 4-pin CHA_FAN)

Connect the fan cables to the fan connectors on the motherboard, ensuring that the black wire of each cable matches the ground pin of the connector.

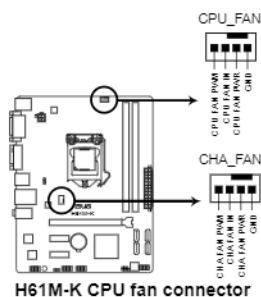

Do not forget to connect the fan cables to the fan connectors. Insufficient air flow inside the system may damage the motherboard components. These are not jumpers! Do not place jumper caps on the fan connectors!



- The two fan connectors support fans of maximum 2A (24 W) fan power.
- Both the 4-pin CPU fan and 4-pin chassis fan are supported by the ASUS Fan Xpert feature.

6. USB connectors (10-1 pin USB56, USB78)

These connectors are for USB 2.0 ports. Connect the USB module cable to any of these connectors, then install the module to a slot opening at the back of the system chassis. These USB connectors comply with USB 2.0 specification that supports up to 480 Mbps connection speed.

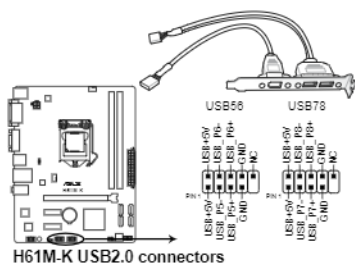

Never connect a 1394 cable to the USB connectors. Doing so will damage the motherboard!



The USB module cable is purchased separately.

7. System panel connector (10-1 pin F_PANEL)

This connector supports several chassis-mounted functions.

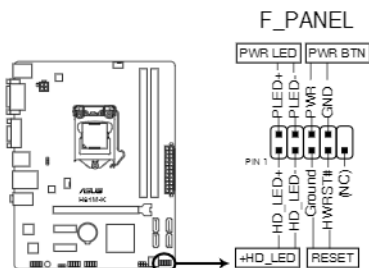

H61M-K System panel connector

- **System power LED (2-pin +PWR_LED-)**

This 2-pin connector is for the system power LED. Connect the chassis power LED cable to this connector. The system power LED lights up when you turn on the system power, and blinks when the system is in sleep mode.

- **Hard disk drive activity LED (2-pin +HDD_LED-)**

This 2-pin connector is for the HDD Activity LED. Connect the HDD Activity LED cable to this connector. The IDE LED lights up or flashes when data is read from or written to the HDD.

- **Power/Soft-off button (2-pin PWR_BTN)**

This 2-pin connector is for the system power button.

- **Reset button (2-pin RESET)**

This 2-pin connector is for the chassis-mounted reset button for system reboot without turning off the system power.

8. Speaker connector (4-pin SPEAKER)

The 4-pin connector is for the chassis-mounted system warning speaker. The speaker allows you to hear system beeps and warnings.

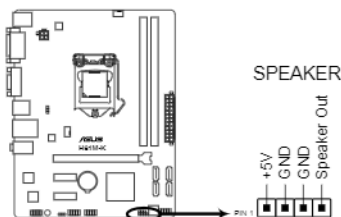

H61M-K Speaker Out Connector

1.9 Software support

1.9.1 Installing an operating system

This motherboard supports Windows® XP / Windows® Vista / Windows® 7 / Windows® 8 Operating Systems (OS). Always install the latest OS version and corresponding updates to maximize the features of your hardware.



- Motherboard settings and hardware options vary. Refer to your OS documentation for detailed information.
- Ensure that you install Windows® XP Service Pack 3 or later versions / Windows® Vista Service Pack 1 or later versions before installing the drivers for better compatibility and system stability.

1.9.2 Support DVD information

The Support DVD that comes with the motherboard package contains the drivers, software applications, and utilities that you can install to avail all motherboard features.



The contents of the Support DVD are subject to change at any time without notice. Visit the ASUS website at www.asus.com for updates.

To run the Support DVD

Place the Support DVD into the optical drive. If Autorun is enabled in your computer, the DVD automatically displays the Specials screen. Click Drivers, Utilities, Make Disk, Manual, and Contact tabs to display their respective menus.



The following screen is for reference only.



Click an icon to display Support DVD/motherboard information

Click an item to install



If Autorun is NOT enabled on your computer, browse the contents of the Support DVD to locate the file ASSETUP.EXE from the BIN folder. Double-click the ASSETUP.EXE to run the DVD.

BIOS information

2

2.1 Managing and updating your BIOS



Save a copy of the original motherboard BIOS file to a USB flash disk in case you need to restore the BIOS in the future. Copy the original motherboard BIOS using the ASUS Update utility.

2.1.1 ASUS Update utility

The ASUS Update is a utility that allows you to manage, save, and update the motherboard BIOS in Windows® environment.



- ASUS Update requires an Internet connection either through a network or an Internet Service Provider (ISP).
 - This utility is available in the support DVD that comes with the motherboard package.
-

Installing ASUS Update

To install ASUS Update:

1. Place the support DVD in the optical drive. The **Specials** menu appears.
2. Click the **Utilities** tab, then click **AI Suite II**.
3. Follow the onscreen instructions to complete the installation.



Quit all Windows® applications before you update the BIOS using this utility.

Updating the BIOS

To update the BIOS:

1. From the Windows® desktop, click **Start > Programs > ASUS > AI Suite II > AI Suite II X.XX.XX** to launch the AI Suite II utility. The AI Suite II Quick Bar appears.
2. Click **Update** button from the Quick Bar, and click **ASUS Update** from the popup menu. The **ASUS Update** main screen appears. From the list, select either of the following methods:

Updating from the Internet

- a. Select **Update BIOS from the Internet**, then click **Next**.
- b. Select the ASUS FTP site nearest you to avoid network traffic, then click **Next**.
- c. From the FTP site, select the BIOS version that you wish to download then click **Next**.



The ASUS Update utility is capable of updating itself through the Internet. Always update the utility to avail all its features.

Updating from a BIOS file

- a. Select **Update BIOS from file**, then click **Next**.
 - b. Locate the BIOS file from the **Open** window, then click **Open**.
3. Follow the onscreen instructions to complete the updating process.

2.1.2 ASUS EZ Flash 2

The ASUS EZ Flash 2 feature allows you to update the BIOS without using an OS-based utility.



Before you start using this utility, download the latest BIOS file from the ASUS website at www.asus.com.

To update the BIOS using EZ Flash 2:

1. Insert the USB flash disk that contains the latest BIOS file to the USB port.
2. Enter the **Advanced Mode** of the BIOS setup program. Go to the **Tool** menu to select **ASUS EZ Flash 2 Utility** and press <Enter> to enable it.
3. Press <Tab> to switch to the **Drive** field.
4. Press the Up/Down arrow keys to find the USB flash disk that contains the latest BIOS, and then press <Enter>.
5. Press <Tab> to switch to the **Folder Info** field.
6. Press the Up/Down arrow keys to find the BIOS file, and press <Enter> to perform the BIOS update process. Reboot the system when the update process is done.



-
- This function supports USB flash disks with FAT 32/16 format and single partition only.
 - DO NOT shut down or reset the system while updating the BIOS to prevent system boot failure!
-

2.1.3 ASUS CrashFree BIOS 3 utility

The ASUS CrashFree BIOS 3 is an auto recovery tool that allows you to restore the BIOS file when it fails or gets corrupted during the updating process. You can restore a corrupted BIOS file using the motherboard support DVD or a USB flash drive that contains the updated BIOS file.



-
- Before using this utility, rename the BIOS file in the removable device into **H61M-K.CAP**.
 - The BIOS file in the support DVD may not be the latest version. Download the latest BIOS file from the ASUS website at www.asus.com.
-

Recovering the BIOS

To recover the BIOS:

1. Turn on the system.
2. Insert the support DVD to the optical drive or the USB flash drive that contains the BIOS file to the USB port.
3. The utility automatically checks the devices for the BIOS file. When found, the utility reads the BIOS file and enters ASUS EZ Flash 2 utility automatically.
4. The system requires you to enter BIOS Setup to recover BIOS setting. To ensure system compatibility and stability, we recommend that you press <F5> to load default BIOS values.



DO NOT shut down or reset the system while updating the BIOS! Doing so can cause system boot failure!

2.1.4 ASUS BIOS Updater

ASUS BIOS Updater allows you to update BIOS in DOS environment. This utility also allows you to copy the current BIOS file that you can use as a backup when the BIOS fails or gets corrupted during the updating process.



The succeeding utility screens are for reference only. The actual utility screen displays may not be same as shown.

Before updating BIOS

1. Prepare the motherboard support DVD and a USB flash drive in FAT32/16 format and single partition.
2. Download the latest BIOS file and BIOS Updater from the ASUS website at <http://support.asus.com> and save them on the USB flash drive.



NTFS is not supported under DOS environment. Do not save the BIOS file and BIOS Updater to a hard disk drive or USB flash drive in NTFS format.

3. Turn off the computer and disconnect all SATA hard disk drives (optional).

Booting the system in DOS environment

1. Insert the USB flash drive with the latest BIOS file and BIOS Updater to the USB port.
2. Boot your computer. When the ASUS Logo appears, press <F8> to show the **BIOS Boot Device Select Menu**. Insert the support DVD into the optical drive and select the optical drive as the boot device.



3. When the Make Disk menu appears, select the FreeDOS command prompt item by pressing the item number.
4. At the FreeDOS prompt, type d: and press <Enter> to switch the disk from Drive C (optical drive) to Drive D (USB flash drive).



Updating the BIOS file

To update the BIOS file using BIOS Updater:

1. At the FreeDOS prompt, type **bupdater /pc /g** and press <Enter>.

```
D:\>bupdater /pc /g
```

2. The BIOS Updater screen appears as below.

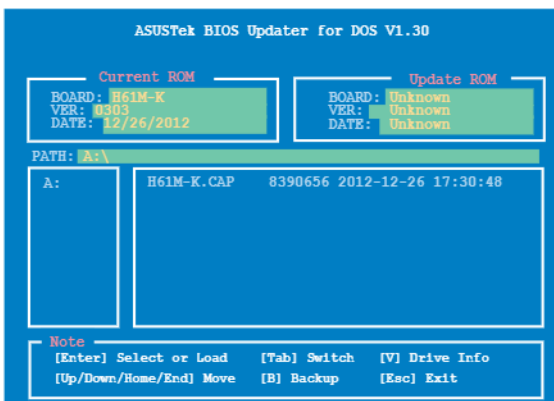

3. Press <Tab> to switch between screen fields and use the <Up/Down/Home/End> keys to select the BIOS file and press <Enter>. BIOS Updater checks the selected BIOS file and prompts you to confirm BIOS update.



4. Select Yes and press <Enter>. When BIOS update is done, press <ESC> to exit BIOS Updater. Restart your computer.



DO NOT shut down or reset the system while updating the BIOS to prevent system boot failure!



- For BIOS Updater version 1.30 or later, the utility automatically exits to the DOS prompt after updating BIOS.
- Ensure to load the BIOS default settings to ensure system compatibility and stability. Select the Load Optimized Defaults item under the Exit menu. Refer to section **2.9 Exit menu** for details.
- Ensure to connect all SATA hard disk drives after updating the BIOS file if you have disconnected them.

2.2 BIOS setup program

Use the BIOS Setup program to update the BIOS or configure its parameters. The BIOS screens include navigation keys and brief online help to guide you in using the BIOS Setup program.

Entering BIOS Setup at startup

To enter BIOS Setup at startup:

- Press <Delete> during the Power-On Self Test (POST). If you do not press <Delete>, POST continues with its routines.

Entering BIOS Setup after POST

To enter BIOS Setup after POST:

- Press <Ctrl>+<Alt>+ simultaneously.
- Press the reset button on the system chassis.
- Press the power button to turn the system off then back on. Do this option only if you failed to enter BIOS Setup using the first two options.



Using the power button, reset button, or the <Ctrl>+<Alt>+ keys to force reset from a running operating system can cause damage to your data or system. We recommend to always shut down the system properly from the operating system.



-
- The BIOS setup screens shown in this section are for reference purposes only, and may not exactly match what you see on your screen.
 - Visit the ASUS website at www.asus.com to download the latest BIOS file for this motherboard.
 - Ensure that a USB mouse is connected to your motherboard if you want to use the mouse to control the BIOS setup program.
 - If the system becomes unstable after changing any BIOS setting, load the default settings to ensure system compatibility and stability. Select the **Load Optimized Defaults** item under the Exit menu. See section 2.9 **Exit Menu** for details.
 - If the system fails to boot after changing any BIOS setting, try to clear the CMOS and reset the motherboard to the default value. See section 1.7 **Jumpers** for information on how to erase the RTC RAM.
-

BIOS menu screen

The BIOS setup program can be used under two modes: **EZ Mode** and **Advanced Mode**. You can change modes from the **Exit** menu or from the Exit/Advanced Mode button in the EZ Mode/Advanced Mode screen.

EZ Mode

By default, the **EZ Mode** screen appears when you enter the BIOS setup program. The **EZ Mode** provides you an overview of the basic system information, and allows you to select the display language, system performance mode and boot device priority. To access the **Advanced Mode**, click **Exit/Advanced Mode**, then select **Advanced Mode** or press F7 hot key for the advanced BIOS settings.



The default screen for entering the BIOS setup program can be changed. Refer to the **Setup Mode** item in section 2.7 **Boot menu** for details.

ASUS UEFI BIOS Utility - EZ Mode

04:42
Monday 10/19/2009

H61M-K
BIOS Version : 0301
CPU Type : Intel (R) Core (TM) i5-2500 CPU @ 3.30GHz Speed : 3300 MHz
Total Memory : 4096 MB (DDR3 1333MHz)

English

Exit/Advanced Mode

Temperature Voltage Fan Speed

Temperature		Voltage		Fan Speed					
CPU	+113.0°F/+45.0°C	CPU	1.1680	SU	5.1680	CPU FAN	4285RPM	CHA. FAN	N/A
MB	+82.4°F/+28.0°C	3.30V	3.3440	12V	11.9840				

Q-Fan Control

Quiet Performance Energy Saving Standard Turbo mode

Boot Priority

Use the mouse to drag or keyboard to navigate to decide the boot priority.

Shortcut (F3) Advanced Mode (F7) Boot Menu (F8) Default (F5)

Selects the display language of the BIOS setup program

Displays the CPU/motherboard temperature, CPU/5V/3.3V/12V voltage output, CPU/chassis fan speed

Exits the BIOS setup program without saving the changes, saves the changes and resets the system, or enters the Advanced Mode

Selects the boot device priority

Displays the Advanced mode menus

Silent mode

Standard mode

Selects the boot device priority

Loads optimized default

Selects the Advanced mode functions

Displays the system properties of the selected mode on the right hand side

Turbo mode



- The boot device options vary depending on the devices you installed to the system.
- The **Boot Menu (F8)** button is available only when the boot device is installed to the system.

Advanced Mode

The Advanced Mode provides advanced options for experienced end-users to configure the BIOS settings. The figure below shows an example of the **Advanced Mode**. Refer to the following sections for the detailed configurations.



To access the EZ Mode, click **Exit**, then select **ASUS EZ Mode**.

Back button Menu items Menu bar Configuration fields General help

ASUS UEFI BIOS Utility - Advanced Mode Exit

Main Ai Tweaker Advanced Monitor Boot Tool

Back Advanced \ CPU Configuration >

Processor Speed 3100 Mhz
Processor Stepping 20fa6
Microcode Revision Not loaded
L1 Data Cache 32 KB x 4
L1 Code Cache 32 KB x 4
L2 Cache 256 KB x 4
L3 Cache 6144 KB
Processor Cores 4
Intel HT Technology Not Supported
CPU Ratio Range Execute Disable Bit
CPU Current Ratio Disabled
 Enabled

Intel Adaptive Thermal Monitor
Active Processor Cores
Limit CPUID Maximum
Execute Disable Bit
Intel Virtualization Technology
Hardware Prefetcher
Adjacent Cache Line Prefetch
> CPU Power Management Configuration

++: Select Screen
F1: Select Item
Enter: Select
+/-: Change Dpt.
F1: General Help
F2: Previous Values
F3: Shortcut
F5: Optimized Defaults
F10: Save ESC: Exit
F12: Print Screen

Version 2.10.1208. Copyright (C) 2012 American Megatrends, Inc.

Submenu item Pop-up window Scroll bar Navigation keys

Menu bar

The menu bar on top of the screen has the following main items:

Main	For changing the basic system configuration
Ai Tweaker	For changing the overclocking settings
Advanced	For changing the advanced system settings
Monitor	For displaying the system temperature, power status, and changing the fan settings
Boot	For changing the system boot configuration
Tool	For configuring options for special functions
Exit	For selecting the exit options and loading default settings

Menu items

The highlighted item on the menu bar displays the specific items for that menu. For example, selecting **Main** shows the Main menu items.

The other items (Ai Tweaker, Advanced, Monitor, Boot, Tool, and Exit) on the menu bar have their respective menu items.

Back button

This button appears when entering a submenu. Press <Esc> or use the USB mouse to click this button to return to the previous menu screen.

Submenu items

A greater than sign (>) before each item on any menu screen means that the item has a submenu. To display the submenu, select the item and press <Enter>.

Pop-up window

Select a menu item and press <Enter> to display a pop-up window with the configuration options for that item.

Scroll bar

A scroll bar appears on the right side of a menu screen when there are items that do not fit on the screen. Press the Up/Down arrow keys or <Page Up> / <Page Down> keys to display the other items on the screen.

Navigation keys

At the bottom right corner of the menu screen are the navigation keys for the BIOS setup program. Use the navigation keys to select items in the menu and change the settings.

General help

At the top right corner of the menu screen is a brief description of the selected item.

Configuration fields

These fields show the values for the menu items. If an item is user-configurable, you can change the value of the field opposite the item. You cannot select an item that is not user-configurable.

A configurable field is highlighted when selected. To change the value of a field, select it and press <Enter> to display a list of options.

2.3 Main menu

The Main menu screen appears when you enter the Advanced Mode of the BIOS Setup program. The Main menu provides you an overview of the basic system information, and allows you to set the system date, time, language, and security settings.

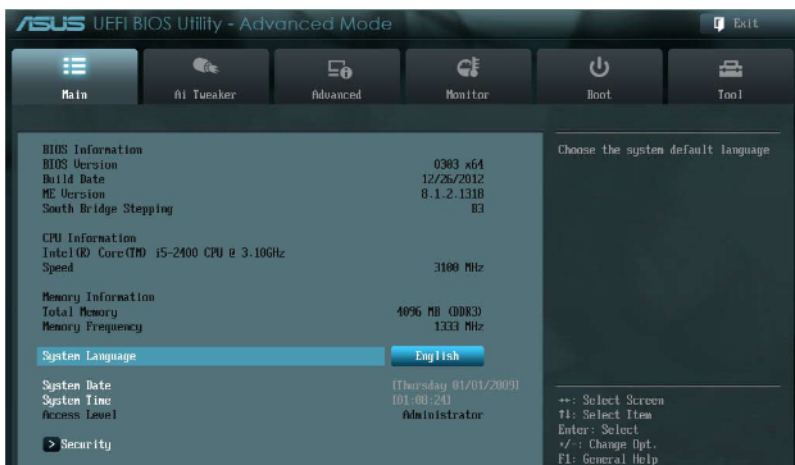

2.3.1 System Language [English]

Allows you to choose the BIOS language version from the options. Configuration options: [English] [Français] [Español] [Deutsch] [Русский] [日本語] [繁體中文] [简体中文]

2.3.2 System Date [Day xx/xx/xxxx]

Allows you to set the system date.

2.3.3 System Time [xx:xx:xx]

Allows you to set the system time.

2.3.4 Security

The Security menu items allow you to change the system security settings.



- If you have forgotten your BIOS password, erase the CMOS Real Time Clock (RTC) RAM to clear the BIOS password. See section 1.7 **Jumpers** for information on how to erase the RTC RAM.
- The **Administrator** or **User Password** items on top of the screen show the default **Not Installed**. After you set a password, these items show **Installed**.

Administrator Password

If you have set an administrator password, we recommend that you enter the administrator password for accessing the system. Otherwise, you might be able to see or change only selected fields in the BIOS setup program.

To set an administrator password:

1. Select the **Administrator Password** item and press <Enter>.
2. From the **Create New Password** box, key in a password, then press <Enter>.
3. Confirm the password when prompted.

To change an administrator password:

1. Select the **Administrator Password** item and press <Enter>.
2. From the **Enter Current Password** box, key in the current password, then press <Enter>.
3. From the **Create New Password** box, key in a new password, then press <Enter>.
4. Confirm the password when prompted.

To clear the administrator password, follow the same steps as in changing an administrator password, but press <Enter> when prompted to create/confirm the password. After you clear the password, the **Administrator Password** item on top of the screen shows **Not Installed**.

User Password

If you have set a user password, you must enter the user password for accessing the system. The **User Password** item on top of the screen shows the default **Not Installed**. After you set a password, this item shows **Installed**.

To set a user password:

1. Select the **User Password** item and press <Enter>.
2. From the **Create New Password** box, key in a password, then press <Enter>.
3. Confirm the password when prompted.

To change a user password:

1. Select the **User Password** item and press <Enter>.
2. From the **Enter Current Password** box, key in the current password, then press <Enter>.
3. From the **Create New Password** box, key in a new password, then press <Enter>.
4. Confirm the password when prompted.

To clear the user password, follow the same steps as in changing a user password, but press <Enter> when prompted to create/confirm the password. After you clear the password, the **User Password** item on top of the screen shows **Not Installed**.

2.4 Ai Tweaker menu

The Ai Tweaker menu items allow you to configure overclocking-related items.



Be cautious when changing the settings of the Ai Tweaker menu items. Incorrect field values can cause the system to malfunction.



The configuration options for this section vary depending on the CPU and DIMM model you installed on the motherboard.

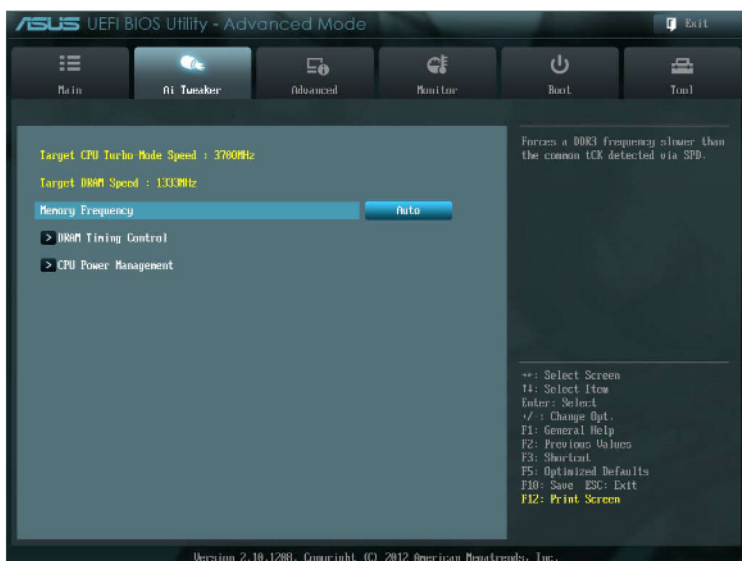

Target CPU Turbo-Mode Speed : xxxxMHz

Displays the target CPU Turbo-Mode speed.

Target DRAM Speed : xxxxMHz

Displays the target DRAM speed.

2.4.1 Memory Frequency [Auto]

Allows you to set the memory operating frequency. Configuration options: [Auto] [DDR3-800MHz] [DDR3-1066MHz] [DDR3-1333MHz] [DDR3-1400MHz] [DDR3-1600MHz] [DDR3-1866MHz] [DDR3-2133MHz] [DDR3-2400MHz]



The configuration options vary with the CPU types installed on the system.



Selecting a very high memory frequency may cause the system to become unstable! If this happens, revert to the default setting.

2.4.2 iGPU Max. Frequency [Auto]

Allows you to set the iGPU maximum frequency. The values range from xxxMHz (by CPU) to 3000MHz with a 50MHz interval. Use <+>/<-> to adjust the value.

2.4.3 DRAM Timing Control

The sub-items in this menu allow you to set the DRAM timing control features. Use the <+> and <-> keys to adjust the value. To restore the default setting, type [auto] using the keyboard and press <Enter>.



Changing the values in this menu may cause the system to become unstable! If this happens, revert to the default settings.

2.4.4 CPU Power Management

The sub-items in this menu allow you to set the CPU ratio and features.

CPU Ratio [Auto]

Allows you to manually adjust the maximum non-turbo CPU ratio. Use <+> and <-> keys or the numeric keypad to adjust the value. The valid value ranges vary according to your CPU model.

Enhanced Intel SpeedStep Technology [Enabled]

Allows you to enable or disable the Enhanced Intel® SpeedStep Technology (EIST).

[Disabled] Disables this function.

[Enabled] The operating system dynamically adjusts the processor voltage and core frequency which may result in decreased average consumption and decreased average heat production.

Turbo Mode [Enabled]

[Enabled] Allows processor cores to run faster than marked frequency in specific conditions.

[Disabled] Disables this function.



The first three items appear only when you set the **Turbo Mode** items to [Enabled].

Long Duration Power Limit [Auto]

Allows you to limit the turbo ratio's long duration power. Use the <+> and <-> keys to adjust the value.

Long Duration Maintained [Auto]

Allows you to maintain the turbo ratio's long duration power. Use the <+> and <-> keys to adjust the value.

Short Duration Power Limit [Auto]

Allows you to limit the turbo ratio's long duration power. Use the <+> and <-> keys to adjust the value.

Primary Plane Current Limit [Auto]

Maximum instantaneous current allowed at any given time for CPU cores. Use <+> and <-> key to adjust the value at 0.125A increment.

Secondary Plane Current Limit [Auto]

Maximum instantaneous current allowed at any given time for Internal Graphics cores. Use <+> and <-> key to adjust the value at 0.125A increment.

2.5 Advanced menu

The Advanced menu items allow you to change the settings for the CPU and other system devices.



Be cautious when changing the settings of the Advanced menu items. Incorrect field values can cause the system to malfunction.



2.5.1 CPU Configuration

The items in this menu show the CPU-related information that the BIOS automatically detects.



The items shown in submenu may be different due to the CPU you installed.

Intel Adaptive Thermal Monitor [Enabled]

- | | |
|------------|--|
| [Enabled] | Enables the overheated CPU to throttle its clock speed to cool down. |
| [Disabled] | Disables the CPU thermal monitor function. |

Active Processor Cores [All]

Allows you to choose the number of CPU cores to activate in each processor package.

Configuration options: [All] [1] [2] [3]

Limit CPUID Maximum [Disabled]

[Enabled] Allows legacy operating systems to boot even without support for CPUs with extended CPUID functions.

[Disabled] Disables this function.

Execute Disable Bit [Enabled]

[Enabled] Enables the No-Execution Page Protection Technology.

[Disabled] Forces the XD feature flag to always return to zero (0).

Intel Virtualization Technology [Disabled]

[Enabled] Allows a hardware platform to run multiple operating systems separately and simultaneously, enabling one system to virtually function as several systems.

[Disabled] Disables this function.

Hardware Prefetcher [Enabled]

[Disabled] Disables this function.

[Enabled] Allows you to turn on /off the Mid Level Cache (L2) streamer prefetcher.

Adjacent Cache Line Prefetch [Enabled]

[Disabled] Disables this function.

[Enabled] Allows a hardware platform to perform adjacent cache line prefetching.

CPU Power Management Configuration

CPU Ratio [Auto]

Allows you to set the ratio between the CPU Core Clock and the BCLK Frequency. Use <+> and <-> keys to adjust the ratio. The valid value ranges vary according to your CPU model.

Enhanced Intel SpeedStep Technology [Enabled]

Allows you to enable or disable the Enhanced Intel® SpeedStep Technology (EIST).

[Disabled] The CPU runs at its default speed.

[Enabled] The operating system controls the CPU speed.

Turbo Mode [Enabled]

Allows you to enable or disable the Intel® Turbo Mode Technology.

[Disabled] Disables this function.

[Enabled] Allows processor cores to run faster than marked frequency in specific condition.

CPU C1E [Auto]

Allows you to enable or disable the CPU C1E.

[Auto] Set this item automatically.

[Disabled] Disables this function.

[Enabled] Enables the C1E support function. This item should be enabled in order to enable the Enhanced Halt State.

CPU C3 Report [Auto]

Allows you to disable or enable the CPU C3 report to OS.

[Auto] Set this item automatically.

[Disabled] Disables this function.

[Enabled] Enables the C3 report function. This item should be enabled in order to enable the Enhanced Halt State.

CPU C6 Report [Auto]

Allows you to disable or enable the CPU C6 report to OS.

[Auto] Set this item automatically.

[Disabled] Disables this function.

[Enabled] Enables the C6 report function. This item should be enabled in order to enable the Enhanced Halt State.

2.5.2 PCH Configuration

High Precision Timer [Enabled]

Allows you to enable or disable the High Precision Event Timer.

Configuration options: [Enabled] [Disabled]

Intel(R) Rapid Start Technology

Intel(R) Rapid Start Technology [Disabled]

Allows you to enable or disable the Intel(R) Rapid Start Technology. Configuration options: [Enabled] [Disabled]



The following three items appear only when you set the **Intel(R) Rapid Start Technology** to [Enabled].

Entry on S3 RTC Wake [Enabled]

Allows you to enable or disable the iFFS invocation upon S3 RTC wake. Configuration options: [Enabled] [Disabled]

Entry After [Immediately]

This item appears only when you set the **Entry on S3 RTC Wake** to [Enabled] and allows you to set the RTC wake timer at S3 entry. Configuration options: [Immediately] [1 minute] [2 minutes] [5 minutes] [10 minutes] [15 minutes] [30 minutes] [1 hour] [2 hours]

Active Page Threshold Support [Disabled]

Allows you to enable or disable the Active Page Threshold Support. Configuration options: [Enabled] [Disabled]

Active Memory Threshold [x]

This item appears only when you set the **Active Page Threshold Support** to [Enabled] and allows you to set the Active Memory Threshold. When the partition size is larger than the Active Page Threshold size, the system will try to support the Intel(R) Rapid Start Technology. When the item is set to zero, the system automatically checks whether the partition size is enough at S3 entry. Key in the desired value using the numeric keypad.

Intel(R) Smart Connect Technology

ISCT Configuration [Disabled]

Allows you to enable or disable the ISCT configuration. Configuration options: [Enabled] [Disabled]

2.5.3 SATA Configuration

While entering Setup, the BIOS automatically detects the presence of SATA devices. The SATA Port items show **Not Present** if no SATA device is installed to the corresponding SATA port.

SATA Mode Selection [AHCI]

Allows you to set the SATA configuration.

- [IDE] Set to [IDE] when you want to use the Serial ATA hard disk drives as Parallel ATA physical storage devices.
- [AHCI] Set to [AHCI] when you want the SATA hard disk drives to use the AHCI (Advanced Host Controller Interface). The AHCI allows the onboard storage driver to enable advanced Serial ATA features that increases storage performance on random workloads by allowing the drive to internally optimize the order of commands.



Due to H61 Chipset limitation, AHCI Mode only works on Windows® Vista / Windows® 7. Please use IDE Mode on Windows® XP.

S.M.A.R.T. Status Check [Enabled]

S.M.A.R.T. (Self-Monitoring, Analysis and Reporting Technology) is a monitor system. When read/write of your hard disk errors occur, this feature allows the hard disk to report warning messages during the POST. This item appears only when you set the previous item to [IDE] or [AHCI]. Configuration options: [Enabled] [Disabled]

Hot Plug [Disabled]

This item only appears when you set the SATA Mode Selection item to [AHCI] and allows you to enable or disable the hot-plug support for each SATA port. Configuration options: [Enabled] [Disabled]

2.5.4 System Agent Configuration

Memory Remap Feature [Enabled]

- [Enabled] Allow you to enable remapping the memory above 4GB.
- [Disabled] Disables this function.

Graphics Configuration

Primary Display [Auto]

Allows you to decide which graphics controller to use as the primary boot device. Configuration options: [Auto] [iGPU] [PCI-E]

iGPU Memory [Auto]

Allows you to select the amount of system memory allocated to DVMT 5.0 used by the iGPU. Configuration options: [Auto] [32M]~[1024M]

Render Standby [Enabled]

Allows you to enable the Intel® Graphics Render Standby support to reduce the iGPU power use when idle. Configuration options: [Disabled] [Enabled]

iGPU Multi-Monitor [Disabled]

Allows you to enable the iGPU Multi-Monitor. For Lucid Virtu MVP function supports, set this item to [Enabled] to empower both integrated and discrete graphics. iGPU shared system memory size is fixed in 64MB.

Configuration options: [Disabled] [Enabled]

2.5.5 USB Configuration

The items in this menu allow you to change the USB-related features.



The USB Devices item shows the auto-detected values. If no USB device is detected, the item shows **None**.

Intel USB2.0 EHCI Controller [Enabled]

[Disabled] Disables the Intel USB2.0 EHCI controller.

[Enabled] Enables the Intel USB2.0 EHCI controller.

Legacy USB Support [Enabled]

[Enabled] Enables the support for USB devices on legacy operating systems (OS).

[Disabled] The USB devices can be used only for the BIOS setup program.

[Auto] Allows the system to detect the presence of USB devices at startup. If detected, the USB controller legacy mode is enabled. If no USB device is detected, the legacy USB support is disabled.

EHCI Hand-off [Disabled]

[Enabled] Enables the support for operating systems without an EHCI hand-off feature.

[Disabled] Disables the function.

USB Single Port Control

USB1~10 [Enabled]

Allows you to enable or disable an individual USB port. Refer to the section **1.3.3 Motherboard layout** in this user manual for the locations of the USB ports.



The USB port numbers may not be arranged in a consecutive order.

2.5.6 Onboard Devices Configuration

HD Audio Controller [Enabled]

- [Enabled] Enables the High Definition Audio Controller.
[Disabled] Disables the controller.



The following two items appear only when you set the **HD Audio Controller** item to [Enabled].

Front Panel Type [HD]

Allows you to set the front panel audio connector (AAFP) mode to legacy AC'97 or high-definition audio depending on the audio standard that the front panel audio module supports.

- [HD] Sets the front panel audio connector (AAFP) mode to high definition audio.
[AC97] Sets the front panel audio connector (AAFP) mode to legacy AC'97.

Realtek LAN Controller [Enabled]

- [Enabled] Enables the Realtek LAN controller.
[Disabled] Disables the controller.

Realtek PXE OPROM [Disabled]

This item appears only when you set the previous item to [Enabled] and allows you to enable or disable the PXE OptionRom of the Realtek LAN controller.

Configuration options: [Enabled] [Disabled]

2.5.7 APM

Restore AC Power Loss [Power Off]

- [Power On] The system goes into on state after an AC power loss.
- [Power Off] The system goes into off state after an AC power loss.
- [Last State] The system goes into either off or on state, whatever the system state was before the AC power loss.

Power On By PCI/PCIE [Disabled]

- [Disabled] Disables the PCI/PCIE devices to generate a wake event.
- [Enabled] Enables the PCI/PCIE devices to generate a wake event.

Power On By RTC [Disabled]

- [Disabled] Disables RTC to generate a wake event.
- [Enabled] When set to [Enabled], the items **RTC Alarm Date (Days)** and **Hour/Minute/Second** will become user-configurable with set values.

RTC Alarm Date (Days)

This item appears only when you set the previous item to [Enabled] and allows you to select RTC alarm time (days). When you set the time to zero, the RTC alarms everyday. Use <+> and <-> keys to adjust the time.

- Hour / - Minute / - Second

Allows you to set the RTC alarm time. Use <+> and <-> keys to adjust the time.

2.5.8 Network Stack

Network Stack [Disabled]

This item allows user to disable or enable the UEFI network stack. Configuration options: [Disabled] [Enabled]



The following two items appear only when you set the previous item to [Enabled].

Ipv4 PXE Support [Enabled]

This item allows user to disable or enable the Ipv4 PXE Boot support. Configuration options: [Disabled] [Enable]

Ipv6 PXE Support [Enabled]

This item allows user to disable or enable the Ipv6 PXE Boot support. Configuration options: [Disabled] [Enable]

2.6 Monitor menu

The Monitor menu displays the system temperature/power status, and allows you to change the fan settings.



Scroll down to display the following items:

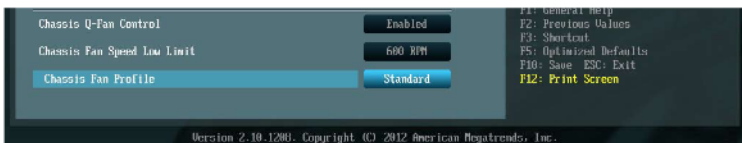

2.6.1 CPU Temperature / MB Temperature [xxx°C/xxx°F]

The onboard hardware monitor automatically detects and displays the CPU and motherboard temperatures. Select **Ignore** if you do not wish to display the detected temperatures.

2.6.2 CPU / Chassis Fan Speed [xxxx RPM] or [Ignore] / [N/A]

The onboard hardware monitor automatically detects and displays the CPU and chassis fan speeds in rotations per minute (RPM). If the fan is not connected to the motherboard, the field shows **N/A**. Select **Ignore** if you do not wish to display the detected speed.

2.6.3 CPU Voltage, 3.3V Voltage, 5V Voltage, 12V Voltage

The onboard hardware monitor automatically detects the voltage output through the onboard voltage regulators. Select **Ignore** if you do not want to detect this item.

2.6.4 CPU Q-Fan Control [Enabled]

[Disabled] Disables the CPU Q-Fan control feature.

[Enabled] Enables the CPU Q-Fan control feature.

CPU Fan Speed Low Limit [200 RPM]

This item appears only when you enable the CPU Q-Fan Control feature and allows you to disable or set the CPU fan warning speed. Configuration options: [Ignore] [100 RPM] [200 RPM] [300 RPM] [400 RPM] [500 RPM]

CPU Fan Profile [Standard]

This item appears only when you enable the CPU Q-Fan Control feature and allows you to set the appropriate performance level of the CPU fan.

[Standard] Sets to [Standard] to make the CPU fan automatically adjust depending on the CPU temperature.

[Silent] Sets to [Silent] to minimize the fan speed for quiet CPU fan operation.

[Turbo] Sets to [Turbo] to achieve maximum CPU fan speed.

[Manual] Sets to [Manual] to assign detailed fan speed control parameters.



The following four items appear only when you set CPU Fan Profile to [Manual].

CPU Upper Temperature [70]

Use the <+> and <-> keys to adjust the upper limit of the CPU temperature. The values range from 20°C to 75°C.

CPU Fan Max. Duty Cycle(%) [100]

Use the <+> and <-> keys to adjust the maximum CPU fan duty cycle. The values range from 20% to 100%. When the CPU temperature reaches the upper limit, the CPU fan will operate at the maximum duty cycle.

CPU Lower Temperature [20]

Displays the lower limit of the CPU temperature.

CPU Fan Min. Duty Cycle(%) [20]

Use the <+> and <-> keys to adjust the minimum CPU fan duty cycle. The values range from 0% to 100%. When the CPU temperature is under 40°C, the CPU fan will operate at the minimum duty cycle.

2.6.5 Chassis Q-Fan Control [Enabled]

[Disabled] Disables the Chassis Q-Fan control feature.

[Enabled] Enables the Chassis Q-Fan control feature.

Chassis Fan Speed Low Limit [600 RPM]

This item appears only when you enable the **Chassis Q-Fan Control** feature and allows you to disable or set the chassis fan warning speed. Configuration options: [Ignore] [200RPM] [300 RPM] [400 RPM] [500 RPM] [600 RPM]

Chassis Fan Profile [Standard]

This item appears only when you enable the **Chassis Q-Fan Control** feature and allows you to set the appropriate performance level of the chassis fan.

[Standard]	Sets to [Standard] to make the chassis fan automatically adjust depending on the chassis temperature.
[Silent]	Sets to [Silent] to minimize the fan speed for quiet chassis fan operation.
[Turbo]	Sets to [Turbo] to achieve maximum chassis fan speed.
[Manual]	Sets to [Manual] to assign detailed fan speed control parameters.



The following four items appear only when you set **Chassis Fan Profile** to [Manual].

Chassis Upper Temperature [70]

Use the <+> and <-> keys to adjust the upper limit of the CPU temperature. The values range from 40°C to 90°C.

Chassis Fan Max. Duty Cycle(%) [100]

Use the <+> and <-> keys to adjust the maximum chassis fan duty cycle. The values range from 60% to 100%. When the chassis temperature reaches the upper limit, the chassis fan will operate at the maximum duty cycle.

Chassis Lower Temperature [40]

Displays the lower limit of the chassis temperature.

CPU Fan Min. Duty Cycle(%) [60]

Use the <+> and <-> keys to adjust the minimum chassis fan duty cycle. The values range from 60% to 100%. When the chassis temperature is under 40°C, the chassis fan will operate at the minimum duty cycle.

2.7 Boot menu

The Boot menu items allow you to change the system boot options.



Scroll down to display the following items:

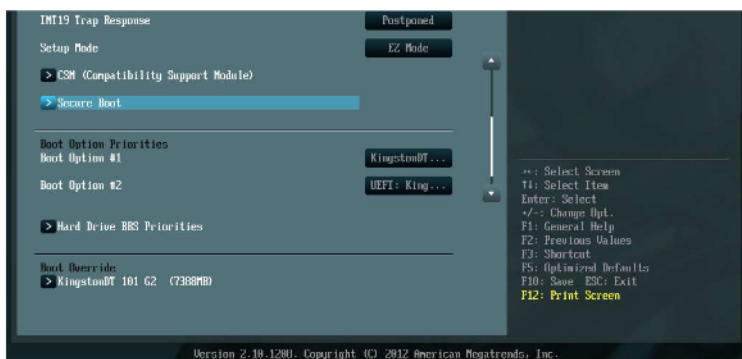

2.7.1 Fast Boot [Enabled]

- [Enabled] Select to accelerate the boot speed.
[Disabled] Select to go back to normal boot.



The following four items appear when you set **Fast Boot** to [Enabled].

USB Support [Partial Initialization]

- [Disabled] All USB devices will not be available until OS boot up for a fastest POST time.
[Full Initialization] All USB devices will be available during POST. This process will extend the POST time.
[Partial Initialization] For a faster POST time, only the USB ports with keyboard and mouse connections will be detected.

PS/2 Keyboard and Mouse Support [Auto]

Select any of these settings when PS/2 keyboard and mouse are installed. These settings only apply when Fast Boot is enabled.

- [Auto] For a faster POST time, PS/2 devices will only be available when the system boots up or rebooted when the PS/2 devices have not been reconnected or changed. If you disconnect or change PS/2 devices before restarting the system, PS/2 devices will not be available and BIOS setup program will not be accessible via PS/2 devices.
[Full Initialization] For full system control, PS/2 devices will be available during POST at any circumstances. This process will extend POST time.
[Disabled] For the fastest POST time, all PS/2 devices will not be available until your computer enters the operating system.

Network Stack Driver Support [Disabled]

- [Disabled] Select to skip the network stack driver from loading during POST.
[Enabled] Select to load the network stack driver during POST.

Next Boot after AC Power Loss [Normal Boot]

- [Normal Boot] Returns to normal boot on the next boot after AC power loss.
[Fast Boot] Accelerates the boot speed on the next boot after AC power loss.

2.7.2 Full Screen Logo [Enabled]

- [Enabled] Enables the full screen logo display feature.
[Disabled] Disables the full screen logo display feature.



Set this item to [Enabled] to use the ASUS MyLogo 2™ feature.

POST Delay Time [3 sec]

This item appears only when you set Full Screen Logo to [Enabled]. This item allows you to select the desired additional POST waiting time to easily enter the BIOS setup. You can only execute the POST delay time during Normal Boot. The values range from 0 to 10 seconds.



This feature will only work under normal boot.

Post Report [5 sec]

This item appears only when you set Full Screen Logo to [Disabled]. This item allows you to select a desired post report waiting time. The values range from 1 to 10 seconds.

2.7.3 Bootup NumLock State [On]

[On] Sets the power-on state of the NumLock to [On].

[Off] Sets the power-on state of the NumLock to [Off].

2.7.4 Wait for 'F1' If Error [Enabled]

When this item is set to [Enabled], the system waits for the F1 key to be pressed when error occurs. Configuration options: [Disabled] [Enabled]

2.7.5 Option ROM Messages [Force BIOS]

[Force BIOS] The third-party ROM messages will be forced to display during the boot sequence.

[Keep Current] The third-party ROM messages will be displayed only if the third-party manufacturer had set the add-on device to do so.

2.7.6 INT19 Trap Response [Postponed]

[Postponed] Allows the option ROMs to trap Interrupt 19 during legacy boot.

[Immediate] Allows the option ROMs to trap Interrupt 19 right away.

2.7.7 Setup Mode [EZ Mode]

[Advanced Mode] Sets Advanced Mode as the default screen for entering the BIOS setup program.

[EZ Mode] Sets EZ Mode as the default screen for entering the BIOS setup program.

2.7.8 CSM (Compatibility Support Module)

Allows you to configure the CSM (Compatibility Support Module) items to fully support the various VGA, bootable devices and add-on devices for better compatibility.

Launch CSM [Enabled]

- [Auto] The system automatically detects the bootable devices and the add-on devices.
- [Enabled] For better compatibility, enable the CSM to fully support the non-UEFI driver add-on devices or the Windows® UEFI mode.
- [Disabled] Disable the CSM to fully support the Windows® Security Update and Security Boot.



The following four items appear when you set Launch CSM to [Enabled].

Boot Devices Control [UEFI and Legacy OpROM]

Allows you to select the type of devices that you want to boot up. Configuration options: [UEFI and Legacy OpROM] [Legacy OpROM only] [UEFI only]

Boot from Network Devices [Legacy OpROM first]

Allows you to select the type of network devices that you want to launch. Configuration options: [Legacy OpROM first] [UEFI driver first] [Ignore]

Boot from Storage Devices [Legacy OpROM first]

Allows you to select the type of storage devices that you want to launch. Configuration options: [Both, Legacy OpROM first] [Both, UEFI first] [Legacy OpROM first] [UEFI driver first] [Ignore]

Boot from PCIe/PCI Expansion Devices [Legacy OpROM first]

Allows you to select the type of PCIe/PCI expansion devices that you want to launch. Configuration options: [Legacy OpROM first] [UEFI driver first]

2.7.9 Secure Boot

Allows you to configure the Windows® Secure Boot settings and manage its keys to protect the system from unauthorized access and malwares during POST.

OS Type [Other OS]

Allows you to select your installed operating system.

[Windows UEFI mode]

Executes the Microsoft® Secure Boot check. Only select this option when booting on Windows® UEFI mode or other Microsoft® Secure Boot compliant OS.

[Other OS]

Get the optimized function when booting on Windows® non-UEFI mode, Windows® Vista/XP, or other Microsoft® Secure Boot non-compliant OS. Only on Windows® UEFI mode that Microsoft® Secure Boot can function properly.



The following item appears when **OS Type** is set to **[Windows UEFI mode]**.

Key Management

This item appears only when you set Secure Boot Mode to [Custom]. It allows you to manage the Secure Boot keys.

Manage the Secure Boot Keys (PK, KEK, db, dbx)

Install Default Secure Boot keys

Allows you to immediately load the default Security Boot keys, Platform key (PK), Key-exchange Key (KEK), Signature database (db), and Revoked Signatures (dbx). The Platform Key (PK) state will change from Unloaded mode to Loaded mode. The settings are applied after reboot or at the next reboot.



Key-exchange Key (KEK) refers to Microsoft® Secure Boot Key database (KEK).

Clear Secure Boot keys

This item appears only when you load the default Secure Boot keys. This item allows you to clear all default Secure Boot keys.

PK Management

The Platform Key (PK) locks and secures the firmware from any non-permissible changes. The system verifies the PK before your system enters the OS.

Load PK from File

Allows you to load the downloaded PK from a USB storage device.

Copy PK to File

Allows you to store the PK to a USB storage device.

Delete PK

Allows you to delete the PK from your system. Once the PK is deleted, all the system's Secure Boot keys will not be active. Configuration options: [Yes] [No]



The PK file must be formatted as a UEFI variable structure with time-based authenticated variable.

KEK Management

The KEK (Key-exchange Key or Key Enrollment Key) manages the Signature database (db) and Revoked Signature database (dbx).



Key-exchange Key (KEK) refers to Microsoft® Secure Boot Key-Enrollment Key (KEK).

Load KEK from File

Allows you to load the downloaded KEK from a USB storage device.

Copy KEK to File

Allows you to store the KEK to a USB storage device.

Delete the KEK

Allows you to delete the KEK from your system. Configuration options: [Yes] [No]

Append KEK from file

Allows you to load the additional KEK from a storage device for an additional db and dbx loaded management.



The KEK file must be formatted as a UEFI variable structure with time-based authenticated variable.

DB Management

The db (Authorized Signature database) lists the signers or images of UEFI applications, operating system loaders, and UEFI drivers that you can load on the single computer.

Load DB from File

Allows you to load the downloaded db from a USB storage device.

Copy DB from file

Allows you to store the db to a USB storage device.

Delete the DB

Allows you to delete the db file from your system. Configuration options: [Yes] [No]

Append DB from file

Allows you to load the additional db from a storage device so that more images can be loaded securely.



The db file must be formatted as a UEFI variable structure with time-based authenticated variable.

DBX Management

The dbx (Revoked Signature database) lists the forbidden images of db items that are no longer trusted and cannot be loaded.

Load DBX from File

Allows you to load the downloaded dbx from a USB storage device.

Copy DBX from file

Allows you to store the dbx to a USB storage device.

Delete the DBX

Allows you to delete the dbx file from your system. Configuration options: [Yes] [No]

Append DBX from file

Allows you to load the additional dbx from a storage device so that more db's images cannot be loaded.



The dbx file must be formatted as a UEFI variable structure with time-based authenticated variable.

2.7.10 Boot Option Priorities

These items specify the boot device priority sequence from the available devices. The number of device items that appears on the screen depends on the number of devices installed in the system.



- To select the boot device during system startup, press <F8> when ASUS Logo appears.
- To access Windows OS in Safe Mode, press <F8> after POST.

2.7.11 Boot Override

These items displays the available devices. The number of device items that appears on the screen depends on the number of devices installed in the system. Click an item to start booting from the selected device.

2.8 Tools menu

The Tools menu items allow you to configure options for special functions. Select an item then press <Enter> to display the submenu.

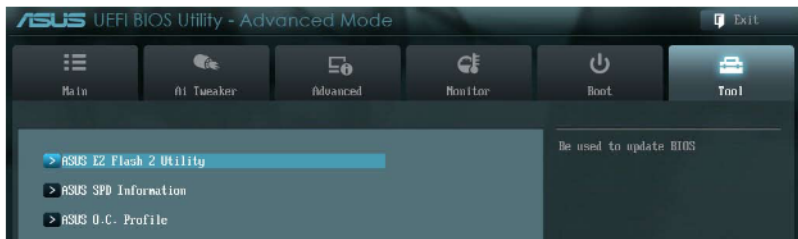

2.8.1 ASUS EZ Flash 2 Utility

Allows you to run ASUS EZ Flash 2. Press [Enter] to launch the ASUS EZ Flash 2 screen.



For more details, see section [2.1.2 ASUS EZ Flash 2](#).

2.8.2 ASUS SPD Information

DIMM Slot # [DIMM_A1]

Displays the Serial Presence Detect (SPD) information of the DIMM module installed on the selected slot. Configuration options: [DIMM_A1] [DIMM_B1]

2.8.3 ASUS O.C. Profile

This item allows you to store or load multiple BIOS settings.



The **Setup Profile Status** items show **Not Installed** if no profile is created.

Label

Allows you to input the label of the setup profile.

Save to Profile

Allows you to save the current BIOS settings to the BIOS Flash, and create a profile. Key in a profile number from one to eight, press <Enter>, and then select **Yes**.

Load from Profile

Allows you to load the previous BIOS settings saved in the BIOS Flash. Key in the profile number that saved your CMOS settings, press <Enter>, and then select **Yes**.



-
- DO NOT shut down or reset the system while updating the BIOS to prevent the system boot failure!
 - We recommend that you update the BIOS file only coming from the same memory/CPU configuration and BIOS version.
-

2.9 Exit menu

The Exit menu items allow you to load the optimal default values for the BIOS items, and save or discard your changes to the BIOS items. You can access the EZ Mode from the Exit menu.

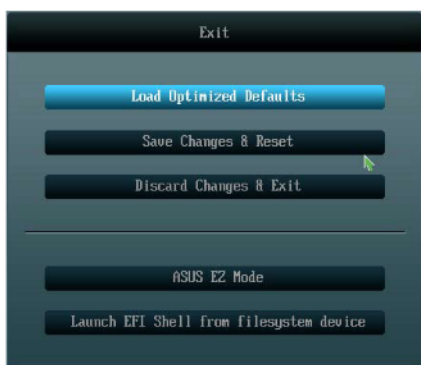

Load Optimized Defaults

This option allows you to load the default values for each of the parameters on the Setup menus. When you select this option or if you press <F5>, a confirmation window appears. Select Yes to load the default values.

Save Changes & Reset

Once you are finished making your selections, choose this option from the Exit menu to ensure the values you selected are saved. When you select this option or if you press <F10>, a confirmation window appears. Select Yes to save changes and exit.

Discard Changes & Exit

This option allows you to exit the Setup program without saving your changes. When you select this option or if you press <Esc>, a confirmation window appears. Select Yes to discard changes and exit.

ASUS EZ Mode

This option allows you to enter the EZ Mode screen.

Launch EFI Shell from filesystem device

This option allows you to attempt to launch the EFI Shell application (shellx64.efi) from one of the available devices that have a filesystem.

Appendices

Notices

Federal Communications Commission Statement

This device complies with Part 15 of the FCC Rules. Operation is subject to the following two conditions:

- This device may not cause harmful interference.
- This device must accept any interference received including interference that may cause undesired operation.

This equipment has been tested and found to comply with the limits for a Class B digital device, pursuant to Part 15 of the FCC Rules. These limits are designed to provide reasonable protection against harmful interference in a residential installation. This equipment generates, uses and can radiate radio frequency energy and, if not installed and used in accordance with manufacturer's instructions, may cause harmful interference to radio communications. However, there is no guarantee that interference will not occur in a particular installation. If this equipment does cause harmful interference to radio or television reception, which can be determined by turning the equipment off and on, the user is encouraged to try to correct the interference by one or more of the following measures:

- Reorient or relocate the receiving antenna.
- Increase the separation between the equipment and receiver.
- Connect the equipment to an outlet on a circuit different from that to which the receiver is connected.
- Consult the dealer or an experienced radio/TV technician for help.



The use of shielded cables for connection of the monitor to the graphics card is required to assure compliance with FCC regulations. Changes or modifications to this unit not expressly approved by the party responsible for compliance could void the user's authority to operate this equipment.

IC: Canadian Compliance Statement

Complies with the Canadian ICES-003 Class B specifications. This device complies with RSS 210 of Industry Canada. This Class B device meets all the requirements of the Canadian interference-causing equipment regulations.

This device complies with Industry Canada license exempt RSS standard(s). Operation is subject to the following two conditions: (1) this device may not cause interference, and (2) this device must accept any interference, including interference that may cause undesired operation of the device.

Cet appareil numérique de la Classe B est conforme à la norme NMB-003 du Canada. Cet appareil numérique de la Classe B respecte toutes les exigences du Règlement sur le matériel brouilleur du Canada.

Cet appareil est conforme aux normes CNR exemptes de licence d'Industrie Canada. Le fonctionnement est soumis aux deux conditions suivantes :

- (1) cet appareil ne doit pas provoquer d'interférences et
- (2) cet appareil doit accepter toute interférence, y compris celles susceptibles de provoquer un fonctionnement non souhaité de l'appareil.

Canadian Department of Communications Statement

This digital apparatus does not exceed the Class B limits for radio noise emissions from digital apparatus set out in the Radio Interference Regulations of the Canadian Department of Communications.

This class B digital apparatus complies with Canadian ICES-003.

VCCI: Japan Compliance Statement

VCCI Class B Statement

情報処理装置等電波障害自主規制について

この装置は、情報処理装置等電波障害自主規制協議会（VCCI）の基準に基づくクラスB情報技術装置です。この装置は家庭環境で使用されることを目的としていますが、この装置がラジオやテレビジョン受信機に近接して使用されると、受信障害を引き起こすことがあります。

取扱説明書に従って正しい取り扱いをして下さい。

KC: Korea Warning Statement

B급 기기 (가정용 방송통신기자재)

이 기기는 가정용(B급) 전자파적합기기로서 주로 가정에서 사용하는 것을 목적으로 하며, 모든 지역에서 사용할 수 있습니다.

*당해 무선설비는 전파혼신 가능성이 있으므로 인명안전과 관련된 서비스는 할 수 없습니다.

REACH

Complying with the REACH (Registration, Evaluation, Authorisation, and Restriction of Chemicals) regulatory framework, we published the chemical substances in our products at ASUS REACH website at <http://csr.asus.com/english/REACH.htm>.



DO NOT throw the motherboard in municipal waste. This product has been designed to enable proper reuse of parts and recycling. This symbol of the crossed out wheeled bin indicates that the product (electrical and electronic equipment) should not be placed in municipal waste. Check local regulations for disposal of electronic products.



DO NOT throw the mercury-containing button cell battery in municipal waste. This symbol of the crossed out wheeled bin indicates that the battery should not be placed in municipal waste.

ASUS Recycling/Takeback Services

ASUS recycling and takeback programs come from our commitment to the highest standards for protecting our environment. We believe in providing solutions for you to be able to responsibly recycle our products, batteries, other components as well as the packaging materials. Please go to <http://csr.asus.com/english/Takeback.htm> for detailed recycling information in different regions.

ASUS contact information

ASUSTeK COMPUTER INC.

Address	15 Li-Te Road, Peitou, Taipei, Taiwan 11259
Telephone	+886-2-2894-3447
Fax	+886-2-2890-7798
E-mail	info@asus.com.tw
Web site	www.asus.com.tw

Technical Support

Telephone	+86-21-38429911
Online support	support.asus.com

ASUS COMPUTER INTERNATIONAL (America)

Address	800 Corporate Way, Fremont, CA 94539, USA
Telephone	+1-812-282-3777
Fax	+1-510-608-4555
Web site	usa.asus.com

Technical Support

Telephone	+1-812-282-2787
Support fax	+1-812-284-0883
Online support	support.asus.com

ASUS COMPUTER GmbH (Germany and Austria)

Address	Harkort Str. 21-23, D-40880 Ratingen, Germany
Fax	+49-2102-959911
Web site	www.asus.de
Online contact	www.asus.de/sales

Technical Support

Telephone	+49-1805-010923*
Support Fax	+49-2102-9599-11
Online support	support.asus.com

* EUR 0.14/minute from a German fixed landline; EUR 0.42/minute from a mobile phone.

DECLARATION OF CONFORMITY

Per FCC Part 2 Section 2.107(f)(6)



Responsible Party Name: Asus Computer International

Address: 800 Corporate Way, Fremont, CA 94539.

Phone/Fax No: (510)79-3777/(510)608-6555

herby declares that the product

Product Name : Motherboard

Model Number : H61M-K

Conforms to the following specifications:

- FCC Part 15, Subpart B, Unintentional Radiators

Supplementary Information:

This device complies with part 15 of the FCC Rules. Operation is subject to the following two conditions: (1) This device may not cause harmful interference, and (2) this device must accept any interference received, including interference that may cause undesired operation.

Representative Person's Name : Steve Chang, President

Signature : Steve Chang
Date : Feb. 25, 2013

Ver. 12/2011

EC Declaration of Conformity



We, the undersigned,

Manufacturer: ASUS/ROBOTIC COMPUTER INC.
 4F, No. 150, LITE-ER, TPE/OU, TAIPEI12, TAIWAN
 Taipei 111, C/P.
 Country: TAIWAN
 Author and responsible in Europe:
 ASUS COMPUTER GmbH
 HAHNSTR. 27/25, 40881 BATHMEN
 Country: GERMANY

declare the following apparatus:

Product name : Motherboard
 Model name : H61M-K

conform with the essential requirements of the following directives :

- 2004/10/EC EMC Directive
 - EN 55022:2008
 - EN 61000-3-2:2008
 - EN 61000-3-0:2007+A1:2009+A2:2010
- 1999/5/EC-R&TTE Directive
 - EN 300 328 V17 (2006-08)
 - EN 300 329 V17 (2006-08)
 - EN 300 330 V17 (2006-08)
 - EN 300 343 V17 (2006-08)
 - EN 300 344 V17 (2006-08)
 - EN 300 345 V17 (2006-08)
 - EN 300 346 V17 (2006-08)
 - EN 300 347 V17 (2006-08)
 - EN 300 348 V17 (2006-08)
 - EN 300 349 V17 (2006-08)
 - EN 300 350 V17 (2006-08)
 - EN 300 351 V17 (2006-08)
 - EN 300 352 V17 (2006-08)
 - EN 300 353 V17 (2006-08)
 - EN 300 354 V17 (2006-08)
 - EN 300 355 V17 (2006-08)
 - EN 300 356 V17 (2006-08)
 - EN 300 357 V17 (2006-08)
 - EN 300 358 V17 (2006-08)
 - EN 300 359 V17 (2006-08)
 - EN 300 360 V17 (2006-08)
 - EN 300 361 V17 (2006-08)
 - EN 300 362 V17 (2006-08)
 - EN 300 363 V17 (2006-08)
 - EN 300 364 V17 (2006-08)
 - EN 300 365 V17 (2006-08)
 - EN 300 366 V17 (2006-08)
 - EN 300 367 V17 (2006-08)
 - EN 300 368 V17 (2006-08)
 - EN 300 369 V17 (2006-08)
 - EN 300 370 V17 (2006-08)
 - EN 300 371 V17 (2006-08)
 - EN 300 372 V17 (2006-08)
 - EN 300 373 V17 (2006-08)
 - EN 300 374 V17 (2006-08)
 - EN 300 375 V17 (2006-08)
 - EN 300 376 V17 (2006-08)
 - EN 300 377 V17 (2006-08)
 - EN 300 378 V17 (2006-08)
 - EN 300 379 V17 (2006-08)
 - EN 300 380 V17 (2006-08)
 - EN 300 381 V17 (2006-08)
 - EN 300 382 V17 (2006-08)
 - EN 300 383 V17 (2006-08)
 - EN 300 384 V17 (2006-08)
 - EN 300 385 V17 (2006-08)
 - EN 300 386 V17 (2006-08)
 - EN 300 387 V17 (2006-08)
 - EN 300 388 V17 (2006-08)
 - EN 300 389 V17 (2006-08)
 - EN 300 390 V17 (2006-08)
 - EN 300 391 V17 (2006-08)
 - EN 300 392 V17 (2006-08)
 - EN 300 393 V17 (2006-08)
 - EN 300 394 V17 (2006-08)
 - EN 300 395 V17 (2006-08)
 - EN 300 396 V17 (2006-08)
 - EN 300 397 V17 (2006-08)
 - EN 300 398 V17 (2006-08)
 - EN 300 399 V17 (2006-08)
 - EN 300 400 V17 (2006-08)
- 2006/65/EC REACH Directive
 - EN 60969-1/A11:2009
 - EN 60969-1/A12:2011
- 2009/24/EC EPB Directive
 - Regulation (EC) No. 1275/2008
 - Regulation (EC) No. 64/2009

EN 55022:2008, EN 61000-3-2:2008, EN 61000-3-0:2007+A1:2009+A2:2010, EN 300 328 V17 (2006-08), EN 300 329 V17 (2006-08), EN 300 330 V17 (2006-08), EN 300 343 V17 (2006-08), EN 300 344 V17 (2006-08), EN 300 345 V17 (2006-08), EN 300 346 V17 (2006-08), EN 300 347 V17 (2006-08), EN 300 348 V17 (2006-08), EN 300 349 V17 (2006-08), EN 300 350 V17 (2006-08), EN 300 351 V17 (2006-08), EN 300 352 V17 (2006-08), EN 300 353 V17 (2006-08), EN 300 354 V17 (2006-08), EN 300 355 V17 (2006-08), EN 300 356 V17 (2006-08), EN 300 357 V17 (2006-08), EN 300 358 V17 (2006-08), EN 300 359 V17 (2006-08), EN 300 360 V17 (2006-08), EN 300 361 V17 (2006-08), EN 300 362 V17 (2006-08), EN 300 363 V17 (2006-08), EN 300 364 V17 (2006-08), EN 300 365 V17 (2006-08), EN 300 366 V17 (2006-08), EN 300 367 V17 (2006-08), EN 300 368 V17 (2006-08), EN 300 369 V17 (2006-08), EN 300 370 V17 (2006-08), EN 300 371 V17 (2006-08), EN 300 372 V17 (2006-08), EN 300 373 V17 (2006-08), EN 300 374 V17 (2006-08), EN 300 375 V17 (2006-08), EN 300 376 V17 (2006-08), EN 300 377 V17 (2006-08), EN 300 378 V17 (2006-08), EN 300 379 V17 (2006-08), EN 300 380 V17 (2006-08), EN 300 381 V17 (2006-08), EN 300 382 V17 (2006-08), EN 300 383 V17 (2006-08), EN 300 384 V17 (2006-08), EN 300 385 V17 (2006-08), EN 300 386 V17 (2006-08), EN 300 387 V17 (2006-08), EN 300 388 V17 (2006-08), EN 300 389 V17 (2006-08), EN 300 390 V17 (2006-08), EN 300 391 V17 (2006-08), EN 300 392 V17 (2006-08), EN 300 393 V17 (2006-08), EN 300 394 V17 (2006-08), EN 300 395 V17 (2006-08), EN 300 396 V17 (2006-08), EN 300 397 V17 (2006-08), EN 300 398 V17 (2006-08), EN 300 399 V17 (2006-08), EN 300 400 V17 (2006-08)



(EC conformity marking)

Position : CEO
 Name : Jerry Shen

Jerry Shen

Signature : _____

Declaration Date: Feb. 25, 2013
 Year to begin affixing CE marking: 2013